



# SJ Stephens Associates

ARBORICULTURAL, LANDSCAPE &  
MANAGEMENT CONSULTANTS

Savernake Barn  
Stokke Common  
Great Bedwyn  
Marlborough  
Wiltshire SN8 3LL  
Tel: 01672 871 862  
www.sjstephens.co.uk  
e: info@sjstephens.co.uk

## FOR CONSTRUCTION

# Arboricultural Impact Assessment

- Tree Survey
- Tree Protection Plan
- Arboricultural Method Statement

### At:-

Roath Flood Risk Management Scheme  
Roath Brook  
Cardiff

### On behalf of:-

Nicholas Pearson Associates  
30 Brock Street  
Bath  
BA1 2LN

### Prepared by:

Simon Stephens MA Oxon, Dip  
Arb(RFS), MArborA, C Env. MICFor  
Email: [simon@sjstephens.co.uk](mailto:simon@sjstephens.co.uk)

Report Date: 27<sup>th</sup> November 2017

Project no: 624

## CONTENTS

**NB: Revisions from 28-02-2017 version highlighted in cyan**  
**Revisions from 27-11-2017 highlighted in green**

- 1 BACKGROUND
- 2 SURVEY DETAILS AND SCOPE
- 3 SURVEY LIMITATIONS
- 4 FINDINGS AND PROPOSALS
- 5 ARBORICULTURAL IMPACT ASSESSMENT

### Appendices

- A Site Plan: drawing no: 624-02.1revC4a, 624-02.2revC4a and 624-02.3revC4a
- B Tree Schedule
- C BS 5837:2012 - Trees in relation to Design, Demolition and Construction, Table 1
- D Tree Protection Fencing Detail
- E Photos showing tree pruning

## 1 BACKGROUND

- 1.1 This Arboricultural Impact Assessment relates to the proposed Roath Brook Flood Alleviation scheme, and provides recommendations for the management of trees on the site. It has been instructed by Nicholas Pearson Associates on behalf of Natural Resources Wales.
- 1.2 An initial tree survey was undertaken by Wyn Davies, CMLI, M ArborA, of Mackley Davies Associates between January and March 2013. Further trees were surveyed during April 2014 by Simon Stephens MA Oxon, Dip Arb (RFS), MArborA, C Env, MICFor of SJ Stephens Associates Ltd. All trees were re-inspected by Simon Stephens and Catherine Fforde during July 2015 and surveys updated. This report has been prepared by Simon Stephens.
- 1.3 This survey and report have been prepared in accordance with recommendations provided in BS 5837:2012, Trees in Relation to Design, Demolition and Construction - Recommendations.
- 1.4 Documentation supplied:
  - Topographical Survey
  - Mackley Davies Associates, Tree Survey and Arboricultural Constraints Plan, dated January 2013
  - SJ Stephens Associates Ltd, Tree Constraints Plan drawing ref: 625-01
  - Wall re-alignment details: drawing no.: ROA-RHD-XX-XX-M2-C-1000-NEW STRUCTURES 4 NPA EDIT

- Team Van Oord General Arrangement Plans, drawing nos: ROA-RHD-06-XX-DR-L-1000 rev P0, ROA-RHD-06-XX-DR-L-1001 rev P0, ROA-RHD-07-XX-DR-L-1000 rev P0, ROA-RHD-09-XX-DR-L-1000 rev P0, ROA-RHD-09-XX-DR-L-1001 rev P0, ROA-RHD-11-XX-DR-L-1000 rev P0, ROA-RHD-11-XX-DR-L-1001 rev P0 and ROA-RHD-12-XX-DR-L-1000 rev P0

## 2 SURVEY DETAILS AND SCOPE

- 2.1 The site survey included trees, with a stem diameter over 75mm at 1.5m height, located within the area shown on the Tree Protection Plan included as Appendix A.
- 2.2 Tree inspection took place from ground level with the use of binoculars, sounding hammer and metal probe using the Visual Tree Assessment method (Mattheck & Breloer 1994). The presence and condition of bark and stem wounds, cavities, decay, fungal fruiting bodies and any structural defects that could increase the risk of structural failure were noted.
- 2.3 The suitability of trees for inclusion in the future development was considered, in particular considering the safe useful life expectancy, and sustainability, of trees on the site after development is completed.
- 2.4 Tree details have been added to the plan received which is included as Appendix A. Tree locations have been taken from the topographical survey provided. Where not included on the topographical survey, they have been determined by measuring distances from features shown on the plan, using a laser measuring device. The following information was recorded for each tree, and is shown in the Tree Schedule included as Appendix B:
- **Number:** an identity number for each tree, prefixed with a "T", which cross references locations shown on the plan with the schedule in Appendix B. Where a number of trees, normally of the same species, are located close together and are similar in character and requirements, they have been treated as a Group under a single Number, prefixed with a "G".
  - **Species:** common name.
  - **Tree height:** approximate height in metres.
  - **Stem diameter:** diameter in millimetres, taken at 1.5m above ground. Where there are a number of stems, stem diameters are recorded in the condition column.
  - **Branch spread:** approximate spread in metres to N,S,W and E of the trunk. The approximate branch spread is drawn on the plan.
  - **Canopy clearance:** approximate height of the canopy above ground. Where a significant, low lateral branch is present, its height and direction of growth is included in the Condition column.
  - **Age class:** Young, Semi-mature, Early mature, Mature, Over-mature, Veteran.

- **Physiological Condition:** Good, Fair, Poor, Dead.
- **Condition:** features that affect the safe useful life expectancy and amenity of the tree, including the presence of decay or any physical defect.
- **Management Recommendations:** recommendations to ensure the health and safety of the tree, within the future development.
- **Estimated Remaining Contribution:** <10 years, 10+ years, 20+ years, 40+ years.
- **Category grading:** tree classification taken from BS 5837:2012, Trees in Relation to Construction (see Appendix C for details), as follows:
  - Category U: Unsuitable for retention, trees with less than 10 years life expectancy, normally recommended for removal (Red)
  - Category A: high quality trees, able to make a substantial contribution for at least 40 years. (Green)
  - Category B: moderate quality trees, able to make a significant contribution for at least 20 years. (Blue)
  - Category C: low quality, in adequate condition to remain for at least 10 years, or young trees <150mm stem diameter.(Grey/Uncoloured)

For category A, B and C trees, a subcategory has been allocated, providing information on the reasons for selection of a specific category, as follows:

- Subcategory 1: mainly arboricultural values.
- Subcategory 2: mainly landscape values.
- Subcategory 3: mainly cultural values, including conservation.
- Trees have been classified irrespective of the possible proximity to future construction. The BS5837 category is colour coded, as indicated above, on the plan included as Appendix A.
- **Protection Distance:** the protection distance in metres required to provide the Root Protection Area recommended in BS 5837, assuming a circular area centred on the tree.
- **Root Protection Area (RPA):** the area in m<sup>2</sup>, as recommended in BS5837, to provide sufficient rooting area to ensure tree survival and which, in most situations, should be fenced off to prevent root damage from construction activities.

### **3 SURVEY LIMITATIONS**

- 3.1 No internal decay devices, or other invasive tools to assess tree condition, were used.
- 3.2 No soil excavation or root inspection was carried out.
- 3.3 This survey has not considered the effect that trees or vegetation may have on the structural integrity of future building through subsidence or heave.
- 3.4 The tree survey has been undertaken principally for planning purposes. Although any obvious structural defects have been noted, a full Tree Hazard Assessment has not been carried out.

### **4 FINDINGS AND PROPOSALS**

#### **4.1 Site Overview**

- 4.1.1 The flood alleviation scheme runs through Roath Brook Gardens, Roath Mill Gardens and Waterloo Gardens. These are all areas of critical landscape and environmental importance in the locality. Trees, which are the dominant feature of the gardens, include many rare and important specimens.
- 4.1.2 Following receipt of tree constraints information, the flood alleviation scheme has been designed, incorporating a combination of walls and bunds, to retain as many trees as possible.
- 4.1.3 The Tree Protection Plan, included as Appendix A, shows trees for retention and removal and the proposed scheme together with tree protection measures.

#### **4.2 Tree Work**

- 4.2.1 Details of proposed tree works are included in the Tree Schedule included as Appendix B.
- 4.2.2 149 **141** trees/tree groups (including T139 and G429) are proposed for removal, as detailed in section 5.1 below.

- 4.2.3 Eight trees (tree nos.: 52,111,158,189,266, 267, 342 and 339) have been identified by ecologists as containing suitable features for bats, although no evidence of bats was seen. As a precautionary measure, these trees must be soft felled ie. cutting the tree in sections and gently lowering the sections to the ground.
- 4.2.4 All tree work should be undertaken to the standards set out in BS 3998:2010 British Standard Recommendations for Tree Work.

### 4.3 Tree and Root Protection

- 4.3.1 Root Protection Areas are shown for all trees in the tree schedule attached as Appendix B. They are also shown for all retained trees, as circular areas centred on the trunk, on the plan enclosed as Appendix A. This shows the distance that construction must normally be kept back from a tree, to provide the Root Protection Area recommended in BS 5837.
- 4.3.2 The location of Tree Protection Fencing is shown on the drawing attached as Appendix A. This provides full protection of all Root Protection Areas, other than for:
- trees where No-Dig Construction must be used, as described in section 4.4 below, to protect underlying roots.
  - trees, where Ground Protection Areas have been defined, and roots must be protected as described in section 4.5 below.
  - tree numbers T17, T18, T69, T71, T160, T183, T184, T188, T249, T251, T252, T383, T390, T391 and T399 where there will be some incursion at the edge of the Root Protection Area. The implications of this are considered in section 5 below. Where considered necessary initial hand digging has been specified to minimise root damage, as described in section 4.6 below.
- 4.3.3 Tree Protection Fencing must be from weldmesh panels, at least 2m high, securely fixed, with wire or scaffold clamps, to a rigid framework. This framework must be constructed from scaffold tubes with vertical tubes, at a maximum interval of 3m and driven into the ground at least 0.6m. The structure must be well braced to resist impacts, constructed as per Figure 2 of BS5837:2012, which is reproduced as Appendix D.
- 4.3.4 Tree Protection Fencing must initially be erected around the outer perimeter of the No-Dig areas, where indicated "C" on the drawing while the main construction work for the flood defence work is undertaken, then moved to the inner perimeter, where indicated "L" as landscape work on that particular area commences.

4.3.5 Where the existing river, adjacent to T160 - T163, is to be infilled, it will not be possible to erect Tree Protection Fencing on the steep bank down to the rivers edge. Instead the Tree Protection Fencing must be erected adjacent to the road and temporary 1.2m hi-viz, plastic mesh fencing, supported by steel road pins, or similar, must be erected alongside the river. This can then be moved up the bank as filling of the channel proceeds.

4.3.6 After erection of Tree Protection Fencing for each section, 2 days notice must be given to the Local Planning Authority before any construction, **including any ground work**, starts on site. Tree Protection Fencing must be maintained and retained for the duration of the works, or until such time as agreed in writing with the Local Planning Authority.

4.3.7 Weatherproof notices must be fixed to the Tree Protection Fencing, and maintained, stating:-

**TREE PROTECTION AREA**

**KEEP OUT**

THE FOLLOWING MUST BE OBSERVED BY ALL PERSONS:

- The Protection Fence must not be moved
- No person, machine or plant shall enter the area
- No materials or spoil shall be deposited
  - No excavation shall occur

ANY INCURSION INTO THE PROTECTED AREA MUST BE WITH THE WRITTEN PERMISSION OF THE LOCAL PLANNING AUTHORITY

#### **4.4 No-Dig Construction Areas**

4.4.1 The No-Dig areas, shown hatched dark blue on the Tree Protection Plan, must be constructed without excavation apart from the removal of turf/organic matter, which should be carried out by hand. Excavators, dumpers and other site traffic must not be allowed to track on the No-Dig areas until roots are protected by the No-Dig surfacing.

4.4.2 In areas where levels are to rise, where the edge of flood defence bunds fall at the edge of Root Protection Areas, levels must be made up with a low organic matter granular fill that allows for free water percolation and gaseous exchange. Topsoil must only be used for depths of up to 150mm. It is essential that the movement of rainwater and gases to underlying roots is not impeded. Subsoil should not, therefore, be used.

4.4.3 The existing river, adjacent to T160 - T163, is to be infilled. Following draining of the channel, a permeable geotextile, followed by a three dimensional cellular confinement system (see 4.4.4 below) must be laid and filled with clean (no fines), washed angular, 40/20mm, stone. Silt from the river bed should not be removed. The cellular confinement system should be "rolled out" from the eastern end, filling it with stone as work progresses. No contractors plant must therefore enter the river bed until the cellular confinement system is laid and filled. Following completion of the cellular confinement system base, the drainage pipes can be laid and the channel can be infilled.

4.4.4 Where proposed paths cross the Root Protection Area of retained trees, engineering details for sections of No-Dig construction must avoid localised compaction, using both a two dimensional geogrid, and a three dimensional cellular confinement system as integral components of the sub-base. A typical section is shown on the drawings included as Appendix A. As well as being fit for purpose, the design and methodology must protect tree roots, by ensuring the following:-

- topsoil/turf must be removed carefully by hand to a maximum of 75mm, or less if roots are found nearer the surface.
- following leveling with soil or sand, a permeable, non-woven geotextile membrane, must be laid.
- a suitable two dimensional geogrid, such the TriAx Geogrid supplied by Tensar International ([www.tensar.co.uk](http://www.tensar.co.uk)). or LBO220 Bi-orientated Geogrid supplied by Geosynthetics Ltd ([www.geosyn.co.uk](http://www.geosyn.co.uk)), must be laid over the entire area and underneath the edging.
- pressure treated timber edging boards, supported by driven stakes must be used.
- a suitable cellular confinement system must then be constructed to manufacturers instructions on top of the geogrid. Products that might be considered include Geoweb, supplied by Cooper Clarke Group Ltd (01204 862 222) or Cellweb, supplied by Geosynthetics Ltd (01455 617 139).
- the cellular confinement system must be filled with clean (no fines), washed angular, 40/20mm, stone to provide load support, while allowing air and moisture to permeate to the root zone.
- a further permeable, non-woven geotextile membrane, such as TreetexT300, or an alternative approved product which has similar oil trapping qualities, must be laid over the cellular confinement system.
- a porous, surfacing material, free from contaminants, must then be laid.
- removed turf/topsoil can be used to grade surrounding ground levels.

4.4.5 No-Dig construction will result in an increase in levels. This has been taken account of in all other aspects of the design.



4.4.6 **NB:** The ground within No-Dig Construction areas must be protected until such time as the new hard surfacing provides protection. In the majority of cases the Tree Protection Fencing specified will provide this protection. However, there may be instances where construction access is required to other areas, prior to No-Dig Surfacing being laid. In these cases, ground protection must be provided as detailed in section 4.5 below.

## 4.5 Ground Protection Areas

4.5.1 The Ground Protection Areas shown hatched in cyan on the plan, can be used for general site use, provided ground protection is installed to protect tree roots. Different types of ground protection must be used, as detailed below. ~~The appropriate ground protection for each area will be detailed in the Arboricultural Method Statement to be prepared with the contractor, and approved by the Local Planning Authority, before work commences:-~~

- for pedestrian and light vehicle access, such as vans and small dumpers/excavators, where Trakmats (supplied by the Marwood Group, [www.marwoodgroup.co.uk](http://www.marwoodgroup.co.uk)), Ground-Guards, as supplied by Greentek ([www.greentek.org.uk](http://www.greentek.org.uk)) or similar approved, must be used. These must be interlinked and laid on top of a compressible layer of sand or woodchips, laid onto a permeable geotextile.
- for heavy vehicles, such as lorries and piling rigs, and for major access points, where either Tufftrak, trackpanel, as supplied by Eve Trakway ([www.evetrakway.co.uk](http://www.evetrakway.co.uk)), Trackpanel (see [www.groundtrax.com](http://www.groundtrax.com)) or similar approved, must be used. These must be inter-linked and laid on top of a compressible layer of sand or woodchips, laid onto a permeable geotextile.
- for areas where only pedestrian movement will take place, it will be acceptable for ground to be protected by either 25mm plywood or scaffold boards, on top of a compressible layer of sand or woodchips, laid onto a permeable geotextile.
- alternatively, a cellular confinement system laid over a permeable geotextile, and filled with clean angular stone, type 4/20 (to BS EN 13242 or BS EN 12620), can be used. The depth of the system must follow suppliers recommendations for the maximum axle weight and soil bearing capacity.

4.5.2 In all cases ground protection products must be laid as per manufacturers best practice guidelines.

4.5.3 Any soil within Root Protection Areas that is damaged must be ameliorated by manual forking once the soil has dried, incorporating a mixture of organic compost and zeolite (5-10%) into the surface soil horizon, taking care not to damage roots.

4.5.4 Where existing paths are to be removed within the Root Protection Area of retained trees, an excavator should only be used if it can work only from areas of hardstanding, or from outside the Root Protection Area. A banksman must be present during this operation and excavation should go no deeper than the existing base course and must cease immediately if roots are

found. Once hard surfacing has been removed, the area should immediately be landscaped using good quality topsoil supplied to BS3882:2015. Tree Protection Fencing must then be erected.

## 4.6 Hand Dig Areas

- 4.6.1 Hand dig areas are shown on the Tree Protection Plan for 16 trees: tree numbers T17, T18, T69, T71, T96, T142, T144, T160, T183, T184, T188, T321, T379, T383, T390 and T399. All excavation up to a depth of 0.9m within the Hand Dig Areas, shown shaded/hatched green on the Tree Protection Plan, must be undertaken by hand.
- 4.6.2 All roots over 25mm diameter must be retained, until approval from the arboricultural consultant has been received. This will either be following a site visit or after receipt of photos. Roots must then be neatly severed using secateurs or a pruning saw
- 4.6.3 Within the Root Protection Area of the oak (T399), all roots greater than 25mm diameter must be retained until inspected on site by the arboricultural consultant.
- 4.6.4 Roots must be wrapped in damp hessian while exposed to avoid desiccation.

## 4.7 General measures

- 4.7.1 No construction activity whatsoever must be allowed within Root Protection Areas, other than that specifically described above. On no account must these areas be used for routing of underground services, storage of materials or on-site parking.
- 4.7.2 No mixing of cement, or concrete, or storage of fuel must take place within 10m of retained trees, nor in any position where the slope of the ground could lead to contamination of the Root Protection Area.
- 4.7.3 Fires must not be lit in a position where their flames could extend to within 10m of foliage, branches or trunk.
- 4.7.4 Landscape works carried out within Root Protection Areas must be undertaken with great care so as not to damage shallow roots. Tractor mounted rotovators or other heavy mechanical cultivation should not be used within the Root Protection Areas.
- 4.7.5 A copy of the Tree Protection Plan must be kept on site and should be fully understood by the Site Agent.

## 4.8 Bat roosts

- 4.8.1 The current legislation makes it a criminal offence to disturb, damage or destroy any bat roost or hibernation area. Contractors must be reminded of their responsibilities and should contact the relevant authorities if any signs of bats are found.

## 4.9 Birds

- 4.9.1 The current legislation makes it a criminal offence to disturb nesting birds. The nesting season is generally assumed to be from 1<sup>st</sup> March to 31<sup>st</sup> July, however this can vary depending on species and location. During these months a careful inspection must be made before work commences and works must be postponed if active nests are found.

## 4.10 Arboricultural Supervision

- 4.10.1 A qualified Arboricultural Consultant must be retained during the period of construction to carry out the following:
- to meet with the contractor prior to the commencement of each phase to go through the Arboricultural Method Statement in detail. If any changes are required, a revised Arboricultural Method Statement must be approved by the Local Planning Authority, before work on site commences.
  - to inspect Tree Protection Fencing and ground protection, prior to construction starting on site,
  - to supervise all construction operations that take place within Root Protection Areas
  - routine monthly inspection visits
  - to undertake a tree condition survey 2 years after completion of the project to assess tree health and condition and to make any appropriate recommendations.
  - as necessary, to advise on any issues at the request of the local planning authority, the developer or contractor.

The details of each site visit must be recorded, with copies circulated to the contractor, client, landscape architect and the local authority Tree Officer.

## 5 ARBORICULTURAL IMPACT ASSESSMENT

- 5.1 141 trees / tree groups, categorized as per BS5837 (see Appendix C for details), are proposed for removal:
- Category U – unsuitable for retention: 13 trees.
  - Category C – low quality: 74 trees/groups (including T139 and G429).
  - Category B/C – between categories B and C: 17 trees.
  - Category B – moderate quality: 31 trees

- Tree nos: 32, 39, 100, 106, 109, 111, 148-151, 179, 189, 202, 206, 207, 259, 261-263, 265-267, 268, 272b, 325, 377, 381, 388, 389, 397, 408 and 424.
- Category A-B – between categories A and B: 1 tree
  - T97- an 18m willow, growing on the river bank
- Category A– high quality: 5 trees
  - T373 – a 15m, early mature sycamore
  - T374 – a 16m Norway maple
  - T405 – a 20m oak
  - T409 – a 17m red oak
  - T426 – a 16m beech

**5.2** Protection measures have been specified to protect the Root Protection Areas of all retained trees, apart from the following where some intrusion into Root Protection Areas will take place:-

- T17, T18, T69 and T71 – where the bank will be re-profiled at the edge of the Root Protection Area. Hand digging has been specified.
- T96, T142, T144, T160, T183, T184, T188, T249, T251, T252, T321, T379, T383 and T390 – where the flood defence wall cuts across the edge of the Root Protection Area. For T249 – T252 excavation will be within, or the other side of, the existing path where root growth is less likely. For T96, T142, T144, T160, T183, T184, T188, T321, T379, T383 and T390, hand digging has been specified.
- T391- a willow tree where there will be significant excavation within the Root Protection Areas, but where the tree will be pollarded to avoid instability and to allow them to regenerate. Hand digging has been specified to ensure roots are neatly severed, rather than being ripped up.
- The Oak, T399, where there will be considerable construction activity at the edge of the Root Protection Area around an important tree for retention. Hand digging has been specified, with no roots to be cut until inspected by either the arboricultural consultant or the Tree Officer, to ensure all possible care is taken to ensure any damage is minimised.

**5.3** Although removal of the 37 “A” and “B” category trees is regrettable, this is considered the minimum number of trees that must be removed to implement the flood defence scheme. This list is the result of ongoing discussions between the arboricultural consultant and the landscape architects. The removal of the lower category trees will be more than mitigated by the new planting proposed.

**5.4** Protection measures have been specified to protect all retained trees. These will be discussed and developed in detail with the successful contractor, with an Arboricultural Method Statement, including arboricultural supervision, submitted to the Local Planning Authority for approval before work starts.



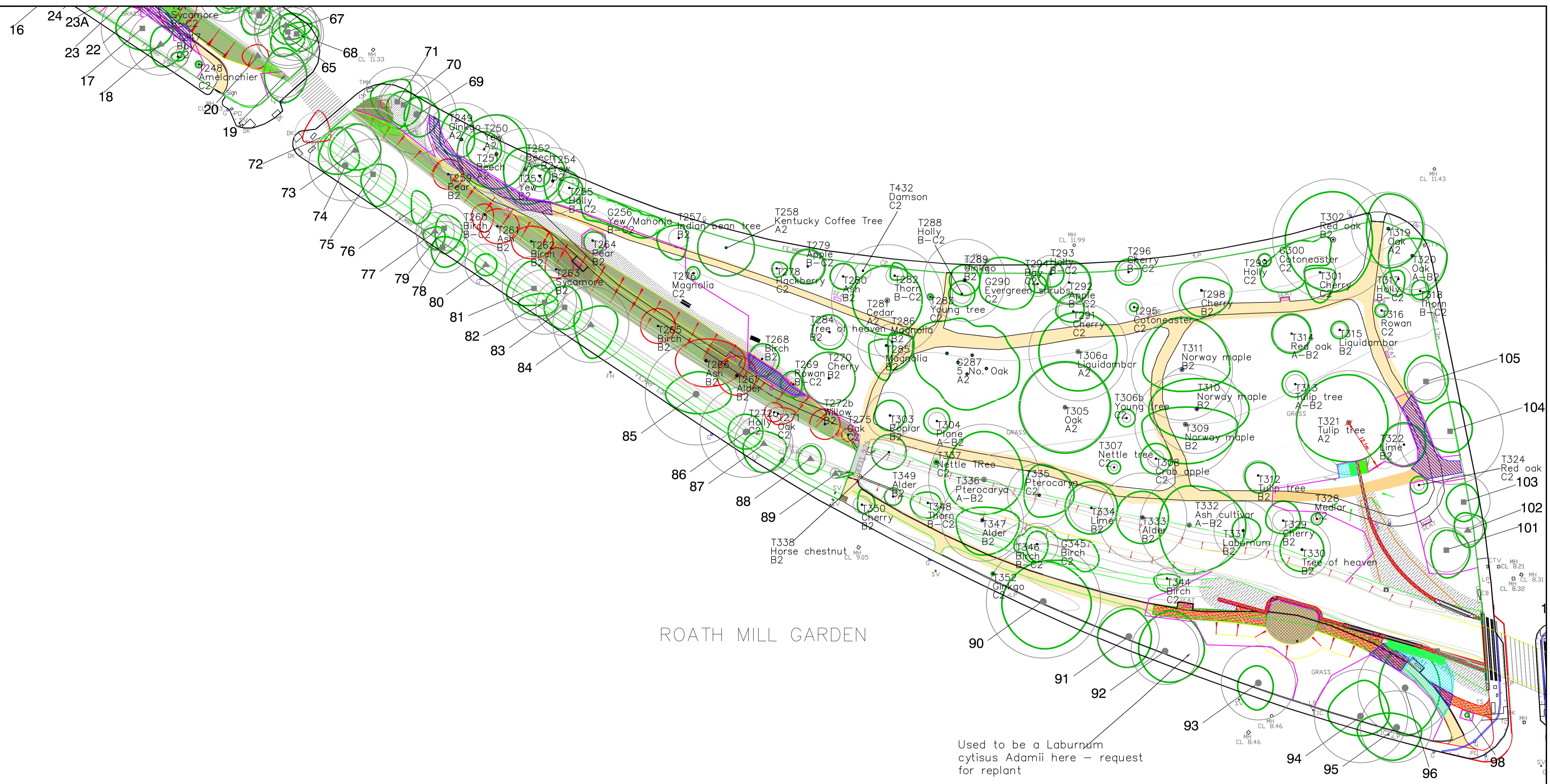

ROATH MILL GARDEN

Used to be a Laburnum cytisus Adamii here - request for replant

KEY (Tree nos: 1-211)

Trees are indicated by symbols below, colour coded to indicate their 'Retention Categories'.

- Category U (defective, negligible or redundant trees)
- Category A (high retention value)
- Category B (moderate retention value)
- Category C (low retention value)

APPROXIMATE crown spread

The nominal ROOT PROTECTION AREA (RPA) of each tree is indicated by a solid line using the colour coding above (or in the case of Category U trees a dashed line).

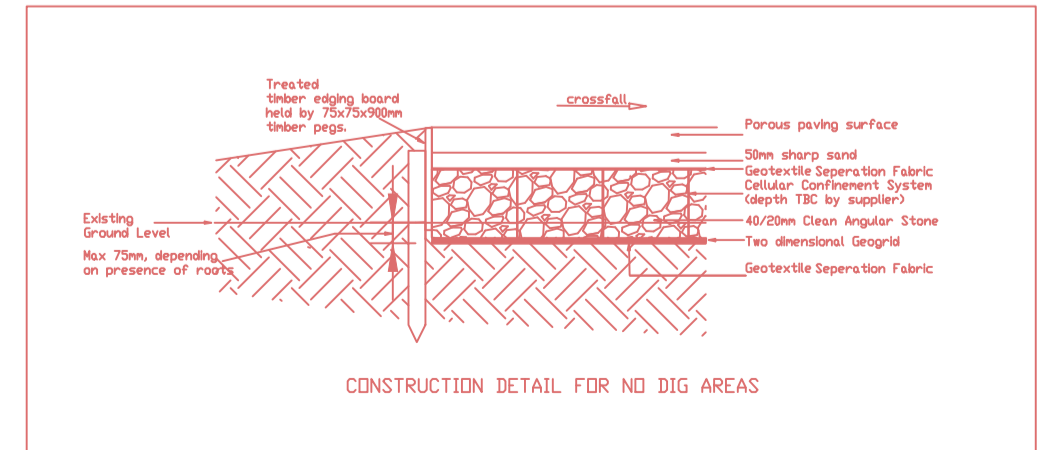

**Key** (Tree nos:247-432)

- Category U
- Category A
- Category B
- Category C
- Crown spread: retained trees
- Trees For Removal
- Root Protection Area
- Tree Protection Fence
- location: construction
- location: landscaping
- No Dig Construction
- Ground Protection Area
- Hand Dig Area

**SJ Stephens Associates**  
 Savernake Barn, Stokke Common  
 Great Bedwyn  
 Marlborough  
 Wiltshire SN8 3LL  
 01672 871862  
 www.sjstephens.co.uk

JOB TITLE  
 ROATH MILL

DRAWING TITLE  
 TREE PROTECTION PLAN  
 - FOR CONSTRUCTION

DRAWING NUMBER	REV
624-02.2	C4A

REVISIONS

SCALE	DATE	DRAWN BY
1:500 at A1	NOV 17	sjs

# APPENDIX A

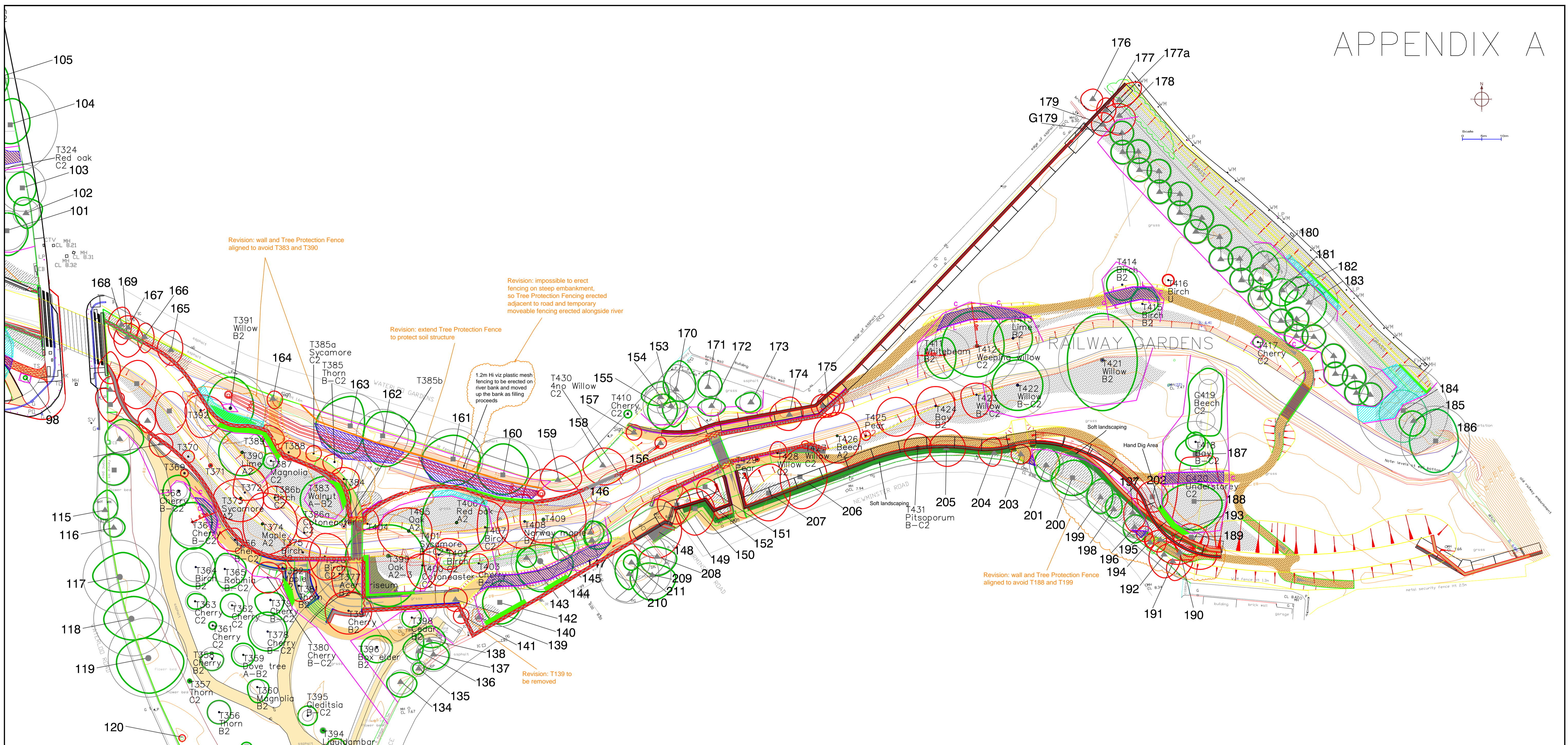
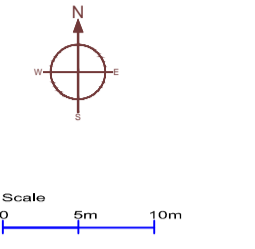

Revision: wall and Tree Protection Fence aligned to avoid T383 and T390

Revision: impossible to erect fencing on steep embankment, so Tree Protection Fencing erected adjacent to road and temporary moveable fencing erected alongside river

Revision: extend Tree Protection Fence to protect soil structure

1.2m Hi viz plastic mesh fencing to be erected on river bank and moved up the bank as filling proceeds

Revision: wall and Tree Protection Fence aligned to avoid T188 and T199

Revision: T139 to be removed

### KEY (Tree nos: 1-211)

Trees are indicated by symbols below, colour coded to indicate their 'Retention Categories'.

- Category U (defective, negligible or redundant trees)
- Category A (high retention value)
- Category B (moderate retention value)
- Category C (low retention value)

APPROXIMATE crown spread

The nominal ROOT PROTECTION AREA (RPA) of each tree is indicated by a solid line using the colour coding above (or in the case of Category U trees a dashed line).

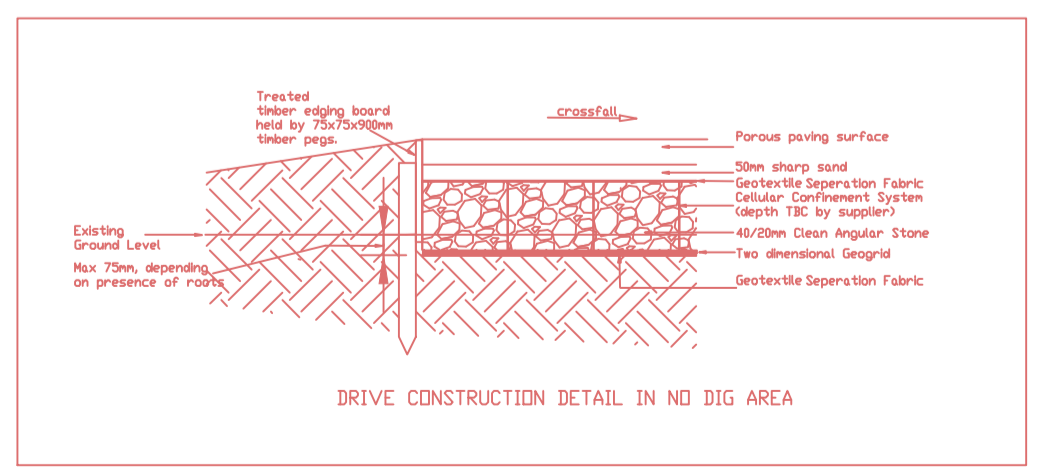

**Key (Tree nos:247-432)**

- Category U
- Category A
- Category B
- Category C
- Crown spread: retained trees
- Trees For Removal
- Root Protection Area
- Tree Protection Fence
- location: construction
- location: landscaping
- No Dig Construction
- Ground Protection Area
- Hand Dig Area

**SJ Stephens Associates**  
 Savernake Barn, Stokke Common  
 Great Bedwyn  
 Marlborough  
 Wiltshire SN8 3LL  
 01672 871862  
 www.sjstephens.co.uk

JOB TITLE  
 ROATH MILL

DRAWING TITLE  
 TREE PROTECTION PLAN  
 - FOR CONSTRUCTION

DRAWING NUMBER	REV
624-02.3	C4A

REVISIONS

SCALE	DATE	DRAWN BY
1:500 at A1	NOV 17	sjs

Roath Brook

Tree Works  
BS 5837 Tree Schedule

Tag nos	Tree/Group No.	Species	Height (m)	Stem Diam. at 1.5m (mm)	Branch Spread (m)				Canopy Clearance (m)	Age Class	Observations <b>ADDITIONAL COMMENTS FROM 01-11-2017 VISIT</b>	Required Tree works. <b>Green text: works for implementation by Cardiff Parks. Red text: Revised works</b>	Estimated Remaining Contribution (years)	BS 5837 Category Grading	Protection Distnce (m)	Tree Protect. Area (m2)	Date of Change
					N	S	E	W									
<b>Roath Brook Gardens:</b>																	
	1	Nettle tree	16.5	890	6	5	7	5.5	4	LM	Branches interfering with BT line, canopy overhanging gable of adjacent house. Small amounts of minor deadwood in canopy. Foliage yellowing throughout crown.		40+	Ai	10.7	333	
117	2	Balkan maple Acer hyrcanum	13	760	7.5	4	8	7	3.5	LM	Exposed buttress roots growing into railings, minor bark splitting, minor decay in old pruning wound at 3.0m, large heavy limb over road. Hung up branch in crown. Minor deadwood.	Remove hung up branch. <b>REMOVE LOW LATERAL BRANCH (100mm)</b>	20-40	Bi	9.1	243	01/11/17
118	3	Lime	19	830	7	8.5	6	4	3.5	LM	Lower branch tips pruned over path, dense ivy on main stem.	<b>LIFT CANOPY OVER PATH TO PROVIDE 3.5M CLEARANCE (BRANCHES &lt;70mm)</b>	40+	Ai	10.0	333	01/11/17
	4	Birch	14	430	6	5	6	3	3.5	M	Numerous witches' broom throughout canopy. Unusual variety. Declining. Minor deadwood.		15-30	Bi	5.2	85	
119	5	Chinese cedar	14.5	645	7	3.5	5	3.5	3.5	M	Significant amount of large diameter deadwood, tree in decline. Very little live crown.	Remove.	<10	U	7.7	186	
120	6	Lime	15	670	8	5.5	5.5	5	3.5	M	Reasonable form with sucker growth at base. Unidentified species. Hanging deadwood. Horse chestnut scale.	<b>LIFT CANOPY OVER PATH TO PROVIDE 3.5M CLEARANCE (BRANCHES &lt;70mm)</b>	40+	Ai	8.0	191	01/11/17
	7	Plane	4.5	110	1	1	1.5	1	2.5	Y		Remove tree stake.	40+	Ci	1.3	3	
121	8	Kentucky coffee tree	13.5	500	5	5.5	5	5	4	M	Large pruning wound at 3.0m on roadside, tree adjacent to street light. Declining, with dieback at branch extremities. <b>LITTLE LIVE GROWTH NOW REMAINING</b>	Remove deadwood. Re-inspect within 18 months. <b>FELL</b>	20-40	U	6.0	109	23/11/17
122	9	Oak	20	950	9	7.5	8	8.5	3.5	LM	Large spreading specimen, ivy on main stem. Some yellowing foliage. Occasional pruning wounds. Deadwood of up to 175mm diameter.	Remove hanging branch and deadwood. <b>REMOVE STORM DAMAGED, HANGING BRANCH (c120mm diam)</b>	40+	Ai	11.4	445	01/11/17
	10	Maple	10.5	390	4	3	3	3.5	2.5	EM	Reasonable form. Exposed basal roots - some damaged.		40+	Bi	4.7	53	
123	11	Ash	14.5	680	8	8	6.5	7	3	LM	On low bank adjacent to railings, good form, exposed & decayed buttress roots. Extensive basal decay.	Remove to prevent risk from future failure.	<10	U	8.2	191	
124	12	Amur cork tree	14.5	420	6	3.5	6	1.5	3.5	M	Slight lean to east, large branch interfering with street light. Exposed surface roots.	<b>LIFT CANOPY OVER PATH TO PROVIDE 3.5M CLEARANCE (BRANCHES &lt;50mm). REMOVE STORM DAMAGED, HANGING BRANCH OVER FOOT PATH.</b>	20-40	Bi	5.0	75	01/11/17
125	13	Oak	15.5	550	7.5	4	7.5	5	4	M	Significant amounts of moderate/large deadwood.	Remove deadwood.	40+	Bi	6.6	137	



Roath Brook

Tree Works  
BS 5837 Tree Schedule

Tag nos	Tree/ Group No.	Species	Height (m)	Stem Diam. at 1.5m (mm)	Branch Spread (m)				Canopy Cleara nce (m)	Age Class	Observations  <b>ADDITIONAL COMMENTS FROM 01-11-2017 VISIT</b>	Required Tree works. <b>Green text: works for implementation by Cardiff Parks. Red text: Revised works</b>	Estimated Remaining Contribution (years)	BS 5837 Category Grading	Protect ion Distnce (m)	Tree Protect. Area (m2)	Date of Change
					N	S	E	W									
126	14	Wingnut	16	1300	12.5	12	10	8	2.5	O	Very large heavy branches over footpath, significant epicormic growth, suckers at base. Extensive basal growth. Large exposed roots to north. 2.8m clearance over existing footpath. Feature tree. <b>MUST RETAIN AND WORK AROUND LARGE LOW BOUGH. SMALL BRANCHES IN RIVER.</b>		10-20	Aiii	15	707	23/11/17
127	15	Pagoda tree	17	670	11.5	7.5	8	3	4	M	Slight lean to east, tight fork at 4.0m, numerous pruning wounds.	<b>LIFT CANOPY OVER PATH TO PROVIDE 3.5M CLEARANCE (BRANCHES &lt;50mm)</b>	20-40	Bi	8	201	01/11/17
	16	Medlar	3	100	1.5	2.5	1.5	1.5	1.5	Y	Stake & tie, bark damage at base, easily replaced if required. Showing good vigour.		20-40	Ci	1.2	5	
128	17	Lime	19	780	6	7	5	6	4	M	Numerous pruning wounds up to 8.0m, small amount of minor deadwood. Exposed and damaged surface roots. Attractive tree.	<b>LIFT CANOPY OVER PATH TO PROVIDE 3.5M CLEARANCE (2 BRANCHES &lt;25mm)</b>	40+	A-Bi	9.4	249	01/11/17
129	18	Bay	14	600	4	5.5	5	2.5	2.5	M	Ivy on stems.	Remove section of ivy from base. <b>LIFT CANOPY OVER PATH TO PROVIDE 3.5M CLEARANCE (1 BRANCH 10mm)</b>	10-20	Ci	7.2	163	01/11/17
130	19	Ash	10.5	420	6	5	6	4.5	3	M	On riverbank adjacent to bridge. Growing out of vertical section.	<b>REDUCE LOW LIMB TO FORK TO ALLOW CONSTRUCTION ACCESS (100m)</b>	20-40	Bii	5	79	01/11/17
131	20	Thorn	4.5	240#	2.5	2.5	3	3.5	2	M	Congested crown, crossing branches. Crataegus coccinea.	Remove for works.	20-40	Ci	2.9	26	
133	21	Sycamore	17	725	4	4	5.5	3	2.5	M	On edge of river-bank. Multi stem. Minor deadwood.	Remove for works.	20-40	Ci	8.7	238	
134	22	Ash	17	400	3.5	2.5	3	3	6	EM	On edge of river-bank, two stemmed from 4.0m. Crown dieback.	Remove for works.	20-40	Ci	4.8	72	
135	23	Ash	16	360	4	4	4	7	4	EM	On edge of river-bank, low branch over footpath. Crown dieback.	Remove for works.	10-20	Ci	4.3	58	
136	23A	Thorn	8	120	2	2	2	2	1.6	M	Growing under canopy of T23. Not included in original survey by Mackley Davies.	<b>REMOVE FOR WORKS</b>	10-20	C2			01/11/17
138	24	Rowan	6	170	1	1	3	2.5	4	Y	Damaged & decayed stem, significant die-back in canopy.	Remove.	<10	U	2	13	
139	25	Swedish whitebeam	10	620	4.5	4	6	4	2.5	M	Ganoderma Fungal brackets in between root buttresses at base. Extensive deadwood.	Remove.	10-20	Ci	7.4	172	
	26	Magnolia	2.5	<75	0.5	0.5	0.5	0.5	1.5	P	Stake & tie, memorial tree with plaque. Some basal bark damage but showing good vigour and vitality.	Relocate. <b>NB: CAN BE RETAINED IN CURRENT POSITION</b>	20-40	Ci	0.9	3	23/11/17
140	27	Thorn	3.5	235	2.5	3	2.5	2	1	EM	Pruning wounds at 2.0m	Remove for works. <b>NB: CAN BE RETAINED.</b>	10-20	Ci	2.8	25	23/11/17

Tag nos	Tree/Group No.	Species	Height (m)	Stem Diam. at 1.5m (mm)	Branch Spread (m)				Canopy Clearance (m)	Age Class	Observations <b>ADDITIONAL COMMENTS FROM 01-11-2017 VISIT</b>	Required Tree works. <b>Green text: works for implementation by Cardiff Parks. Red text: Revised works</b>	Estimated Remaining Contribution (years)	BS 5837 Category Grading	Protection Distnce (m)	Tree Protect. Area (m2)	Date of Change
					N	S	E	W									
141	28	Amur honeysuckle (Lonicera maackii)	6	365	3.5	5	3.5	4	2.5	M	Die-back and minor deadwood at branch tips. Likely to be a Champion Tree. <b>MUST BE RETAINED.</b>	<b>WORKS DETAIL REQUIRED</b>	10-20	Ci	4.4	61	01/11/17
142	28A	Rowan	2.5	70	1	1	1	1	0.5	SM	Small tree not included in original survey by Mackley Davies.	<b>REMOVE FOR WORKS</b>	10-20	C2			01/11/17
143	28B	Holly	5	70	1	1	1	1	0.3	SM	Small tree not included in original survey by Mackley Davies.	<b>REMOVE FOR WORKS</b>	15-30	C2			01/11/17
144	28C	Lawson cypress	9	400	3	3	3	3	0.6	EM	Leaning over river. Not included in original survey by Mackley Davies.	<b>REMOVE FOR WORKS</b>	10-20	C2			01/11/17
145	29	Osmanthus x burkwoodii	4.5	190	4	4	4	1	2	M	Lean to SE, minor bark wound at 1.5m, pruning wound at 2.5m	Remove for new path.	10-20	Ci	2.3	17	
	30	Holly	3	100	0	0	0	0	0	Y	Dead tree. Stump.		<10	U	1.2	5	
146	31	Holly	4	170	1	1	1	1	1.5	Y	Reasonable form.	Remove for works.	10-20	B-Cii	2	13	
147	32	Norway maple	10	330	2.5	5	5.5	3.5	3.5	EM	Low vigour.	Remove for new path.	15-30	Bi	4	50	
148	33	Norway maple	14	465	4	4	4	6	3	M	Major deadwood throughout canopy. Extensive surface roots.	Remove for works.	20-40	B-Cii	5.6	99	
149	34	Thorn	9	335	0.5	1	5	4	2.5	M	Asymmetrical, suppressed by adjacent tree	Remove for works.	10-20	Cii	4	50	
150	35	Thorn	4	185	2	2	2	2	1	EM	Twisted stem at base, pruning wounds at 1.0m	Remove for works.	10-20	Cii	2.2	15	
151	36	Thorn	4	255	2.5	2.5	2.5	2	2.5	EM	Multi stem. Partially suppressed.	Remove for works.	10-20	Cii	3.1	30	
152	37	Crab apple	10	370	4.5	5	4.5	4	2.5	M	Reasonable form. Extensive minor deadwood. <b>ATTRACTIVE TREE.</b>	Remove for works. <b>NB: RETAIN, BUT LIFT CANOPY OVER PATH TO PROVIDE 3.5M CLEARANCE</b>	10-20	Cii	4.4	61	01/11/17
153	38	Whitebeam	10	410	4	4	4	2	2	M	Leans east over river, three stemmed at 2.5m, tight forks, crossing stems. Basal bark damage.	Remove for works.	20-40	Cii	4.9	75	
154	39	Maple	16.5	625	6	6	7	8	3	M	Minor bark splitting and bleeding, branch ripped out at 4.5m with long stem wound. Deadwood of up to 75mm diameter. Large exposed and damaged surface roots.	Remove for new path.	20-40	Bi	7.5	177	01/11/17
155	40	Whitebeam	7	255	2.5	2	3	2.5	2	EM	Crossing branches in canopy. Basal growth dead - likely as a result of herbicide application.	Remove for works.	20-40	Ci	3.1	30	
156	41	Holly	4	200	2.5	2.5	2.5	2.5	1	Y	Shrubby holly, easily replaced if required.	Remove for works.	20-40	Ci	2.4	18	
	42	Birch	14	375	3	4.5	4	3	4.5	M	Reasonable form. Dead.	Remove. <b>ALREADY REMOVED.</b>	<10	U	4.5	64	01/11/17
	43	Turkish hazel	4.5	200	3	3	1.5	3	2	EM	Good form, suckers at base: Extensive basal growth obscuring inspection of main tree stem.		20-40	B-Cii	2.4	18	
	44	Goat willow	7	370	3	2.5	3	3.5	2	EM	Stems twisted together, split stem at 1.5m -potential hazard. Crown dieback	Remove. <b>STEM REMOVED - WORK NO LONGER REQUIRED</b>	<10	U	4.4	61	01/11/17
	45	Willow	9	260	2.5	4	4	0.5	4	EM	Three stems removed at base, two stems remain, poor form. Extensive basal growth obscuring inspection.	Remove basal growth and re-inspect. <b>BASAL GROWTH ALREADY REMOVED</b>	10-20	B-Cii	3.1	30	01/11/17

Roath Brook

Tree Works  
BS 5837 Tree Schedule

Tag nos	Tree/Group No.	Species	Height (m)	Stem Diam. at 1.5m (mm)	Branch Spread (m)				Canopy Clearance (m)	Age Class	Observations <b>ADDITIONAL COMMENTS FROM 01-11-2017 VISIT</b>	Required Tree works. <b>Green text: works for implementation by Cardiff Parks. Red text: Revised works</b>	Estimated Remaining Contribution (years)	BS 5837 Category Grading	Protection Distnce (m)	Tree Protect. Area (m2)	Date of Change
					N	S	E	W									
157	46	White willow	16.5	945	6	5.5	5.5	5	4	M	Topped at 8.0m with significant re-growth, dense ivy on two stems.	Remove section of ivy from base. Reduce crown to prevent risk of future breakout from attachment points at 8m. <b>LEAVE AS OUTSIDE WORKS AREA. CROWN REDUCTION RECOMMENDATION TO CARDIFF PARKS</b>	10-20	Ci	11.3	401	23/11/17
158		Fallen tree	9	150								REMOVE					01/11/17
	47	Spindle	4.5	180	1.5	1.5	2	2	2.5	Y	Shrubby specimen.		10-20	Ci	2.2	15	
159	48	Weeping willow	15	740	5	8	6	9	2.5	M	Trimmed branch tips over road, ivy on stem. Minor deadwood throughout crown with some up to 100mm. Attractive, feature tree.	Remove section of ivy from base. Remove deadwood over pavement and road.	20-40	Bi	8.9	249	
	49	White willow	14	650	5	5	5	4	2	M	Large stem wound at 0.5m, numerous pruning wounds over road, lean SW over river.		20-40	Ci	7.8	191	
160	50	Sycamore	12	345	2.5	3.5	3.5	3	3	EM	Self-seeded sycamore close to bridge railings. Multi stem - tight forks.	Remove. <b>REMOVAL NOT NOW REQUIRED.</b>	40+	Ci	4.1	53	01/11/17
	51	Alder	7	180	2	2.5	2	3.5	1.5	Y	Easily replaced if required. Cut leaf variety - likely 'Imperialis'.		40+	Ci	2.2	15	
161	52	Dead tree	4	-	-	-	-	-	-	-	Dead trunk, standing stock to 3m	Remove. Soft fell in case of bats. Plant new tree.	<10	U	-	-	
	53	Alder	12	520	3	3	4	3.5	3	M	Dense ivy throughout. Engulfed in ivy. Cut leaf variety likely to be 'Imperialis'.	Remove section of ivy from base. <b>ALREADY DONE</b>	10-20	Ci	6.2	121	01/11/17
	54	Weeping willow	12	800	5	3.5	5	5.5	0.5	M	Slight lean to SW over river. All crown weight to south. Large decay points in main stem.	<b>RECOMMENDATION TO CARDIFF PARKS:</b> Carry out Tree Hazard Assessment to investigate decay points.	20-40	Bi	9.6	290	
162	55	Ash	14.5	690	7.5	7	5	7	2.5	M	Minor deadwood in crown, numerous occluded pruning wounds. Deadwood of up to 100mm diameter over road and pavement. Wide spreading crown.	<b>RECOMMENDATION TO CARDIFF PARKS:</b> Remove deadwood over road and pavement.	20-40	Bi	8.3	216	
163	56	Alder	14.5	840	4	9	6	6	4	M	One stem leaning east over road (growing into railings) cut back at 1.6m, leaving large wound, one stem leaning over river, ivy on lower stems.	Remove section of ivy from base- <b>ALREADY DONE.</b>	20-40	Cii	10.1	320	01/11/17
	57	Scots pine	16	470	4	3	3.5	4	2.5	M	One of a small group of pines.	Remove deadwood over road and pavement. <b>NOT REQUIRED</b>	40+	Bii	5.6	99	01/11/17

Tag nos	Tree/ Group No.	Species	Height (m)	Stem Diam. at 1.5m (mm)	Branch Spread (m)				Canopy Cleara nce (m)	Age Class	Observations  <b>ADDITIONAL COMMENTS FROM 01-11-2017 VISIT</b>	Required Tree works. <b>Green</b> text: works for implementation by Cardiff Parks. <b>Red text: Revised</b> works	Estimated Remaining Contribution (years)	BS 5837 Category Grading	Protect ion Distnce (m)	Tree Protect. Area (m2)	Date of Change	
					N	S	E	W										
164	58	Scots pine	16.5	660	3	4	4.5	3	6	M	Two stemmed from 2.0m, cable ties at 6.0m and 12.0m. Small dead branches.	RECOMMENDATION TO CARDIFF PARKS: Remove deadwood over road and pavement.	40+	Bii	7.9	196	23/11/17	
165	59	Scots pine	3	-	-	-	-	-	-	-	Dead pine stump	Remove stump. <b>NOT REQUIRED</b>	<10	U	-	-	23/11/17	
	59a	Liquidambar	16	450	4	4	5	4	3	M	Splits into 3 co-dominant stems at 4.0m		20-40	Bi	5.4	92		
	60	Scots pine	13.5	500	6	4	4	3	6	M			20-40	Bii	6	113		
	61	Scots pine	14	380	5	3	3.5	3	6	M	Twisted stem		20-40	Bii	4.6	66		
	62	Scots pine	8	205	5	1.5	0	1.5	8	EM	Twisted stem, significant lean to north, poor form, suppressed specimen.		<10	U	2.5	20		
	63	Scots pine	13.5	385	2	3	4	4	5	M			20-40	Bii	4.6	66		
166	64	Scots pine	12	350	3	2	3	3	6	M	Ivy on stem, sparse crown.	Remove section of ivy from base. <b>NOT REQUIRED</b>	20-40	Cii	4.2	55		
	65	Scots pine	14	590	3	3.5	4	4	6	M	Ivy on lower stem.	Remove section of ivy from base. <b>NOT REQUIRED</b>	20-40	Cii	7.1	158		
	66	Scots pine	12	590	2.5	6	3	1.5	6	M	Significant lean east over road, twisted stem. Ivy.	Remove section of ivy from base. <b>NOT REQUIRED</b>	10-20	Cii	7.1	158		
	67	Scots pine	15	640	4	4	3	3.5	10	M	Ivy on lower stem.	Remove section of ivy from base. <b>NOT REQUIRED</b>	20-40	Bii	7.7	186		
	68	Scots pine	14.5	520	2.5	5	4	3	6	M	Three stemmed from 4.0m. Ivy.	Remove section of ivy from base. <b>NOT REQUIRED</b>	20-40	Bii	6.2	121		
<b>Roath Mill Garden: Note - No access to tree numbers 72-88 where behind railings.</b>																		
	69	Ginkgo	17.5	750	4	5	5	3	4.5	M	Numerous pruning wounds N & E sides, numerous burrs.		40+	Ai	9	254		
	70	Robinia	16	495	3	4	5	4	8	M	Slight lean to west, leaning on stem of adjacent tree.		20-40	Bii	5.9	109		
	71	Robinia	16	650	5	3	6	6	6.5	M	Twisted stem, leaning on adjacent trunk, large pruning wounds at 2.5 & 3.0m		20-40	Bii	7.8	191		
167	72	Weeping willow	7.5	480	6	3	0	4	2	M	Large decayed pruning wounds at 2.5m, 3.0m & 5.0m with fungal fruiting brackets. Lean to north over bridge. Main stem severed at approx 7m.	Remove	<10	U	5.8	106		
	73	Ash	15	510	6	6	4.5	5.5	4	EM	Twin stemmed from 0.5m. Minor deadwood throughout crown.		20-40	Ci	6.1	117		
	74	Weeping willow	16	690	8	3	2	6	2	M	Lean north towards bridge, large pruning wounds at 6-8m		20-40	A-Bii	8.3	216		
	75	Weeping willow	16	670	2	5	7	2.5	2	M	Large pruning wound at 4.0m. Bent upper stem.		20-40	Bii	8	201		
168	76	Scots pine	6	325	4	4	3	0	4	EM	Topped at 6.0m leaving poorly structured tree.	RECOMMENDATION TO CARDIFF PARKS: Remove.	<10	U	3.9	48	23/11/17	
	77	Scots pine	8	365	1	2	4	2.5	6	M	Twisted stem, leans south over road.		20-40	Cii	4.4	61		
	78	Scots pine	12	495	2.5	5	4.5	2.5	4	M	One of a group of three pines.		20-40	Bii	5.9	109		

Roath Brook

Tree Works  
BS 5837 Tree Schedule

Tag nos	Tree/Group No.	Species	Height (m)	Stem Diam. at 1.5m (mm)	Branch Spread (m)				Canopy Clearance (m)	Age Class	Observations <b>ADDITIONAL COMMENTS FROM 01-11-2017 VISIT</b>	Required Tree works. <b>Green text: works for implementation by Cardiff Parks. Red text: Revised works</b>	Estimated Remaining Contribution (years)	BS 5837 Category Grading	Protection Distnce (m)	Tree Protect. Area (m2)	Date of Change
					N	S	E	W									
	79	Scots pine	12.5	440	3	4	6	2	3	M	One of a group of three pines.		20-40	Bii	5.3	88	
	80	Lawson cypress	15	400	2.5	2.5	2.5	2.5	2.5	M	Reasonable form, uninspiring specimen. Browning foliage.		20-40	Ci	4.8	72	
194	81	Birch	16	610	6	5	4	6	3	M	Large decayed pruning wound at 2.5m - at base of central stem. Ivy over stem wound	Carry out Tree Hazard Assessment. <b>RECOMMENDATION TO CARDIFF PARKS TO REDUCE CROWN BY 15% TO REDUCE RISK OF FAILURE.</b>	20-40	Bii	7.3	167	23/11/17
195	82	Birch	14	615	2	3	3	6	3	M	Slight lean SW over road. Large wound at 2m to east where a stem has broken out - decay entering main stem - potential failure point.	Carry out Tree Hazard Assessment. <b>RECOMMENDATION TO CARDIFF PARKS TO REDUCE CROWN BY 20% TO REDUCE RISK OF FAILURE.</b>	15-30	Cii	7.4	172	23/11/17
	83	Birch	16	540	5	4	5	4.5	6	M	Ivy on stem and into canopy.	Remove section of ivy from base. <b>ALREADY DONE.</b>	20-40	Bii	6.5	133	01/11/17
169	84	White Poplar	22	725	4	6	7.5	4	4	M	Ivy on three stems, significant lean south for two stems. Dense ivy to mid crown.	Remove section of ivy from base.	20-40	Ci	8.7	238	
170	85	Holm oak	14	975	5	8	4.5	7	4	M	Congested crown at 1.5-2.0m. Multi stem from 1m. Stem wound at approx 7m - over pavement - where a branch has broken out in the past - potential decay point. Deadwood. Attractive tree.	Remove deadwood over road and pavement.	40+	Aii	11.7	430	
	86	Holm oak	14	870	4	4	4	4	4.5	M	One of a group of two. Growing on edge of bank. Minor deadwood. Attractive tree.		40+	Aii	10.4	340	
196	87	Alder	14.5	555	3	5	6.5	4.5	3	M	Numerous pruning wounds with small decay pockets 2.0-4.0m. Dying back. <b>LEANING TO EAST. EXTENSIVE DIEBACK. GANNODERMA FUNGAL BRACKET.</b>	<b>RECOMMENDATION TO CARDIFF PARKS TO FELL.</b>	<10	U	6.7	141	23/11/17
171	88	Alder	8	280	3	2.5	3.5	3	2	EM	Ivy on lower stem to mid crown.	Remove section of ivy from base.	20-40	B-Ci	3.4	36	
	89	Felled															
172	90	Red oak	16	1,130	9	11	11	9.5	6	LM	Large buttress roots exposed, lifting adjacent road kerbs. Deadwood up to 175mm diameter.	<b>RECOMMENDATION TO CARDIFF PARKS: Remove deadwood.</b>	40+	Ai	13.6	539	
173	91	Turkey oak	15	610	6.5	5	7	7	6	M	Small amount of large diameter deadwood in crown.	<b>RECOMMENDATION TO CARDIFF PARKS: Remove deadwood.</b>	40+	Aii	7.3	158	
174	92	Turkey oak	15	670	9	9	7	6	4	M	One of a group of two. Attractive, feature tree.	<b>RECOMMENDATION TO CARDIFF PARKS: Remove deadwood.</b>	40+	Aii	8.0	191	

Roath Brook

Tree Works  
BS 5837 Tree Schedule

Tag nos	Tree/Group No.	Species	Height (m)	Stem Diam. at 1.5m (mm)	Branch Spread (m)				Canopy Clearance (m)	Age Class	Observations <b>ADDITIONAL COMMENTS FROM 01-11-2017 VISIT</b>	Required Tree works. <b>Green text: works for implementation by Cardiff Parks. Red text: Revised works</b>	Estimated Remaining Contribution (years)	BS 5837 Category Grading	Protection Distnce (m)	Tree Protect. Area (m2)	Date of Change
					N	S	E	W									
	93	Ginkgo	18	740	4	3.5	6	4.5	3	M	Good mature specimen. Decay in stem attachment points - high risk of failure to large stems, including those over adjoining pavement and road. Roots lifting adjacent paving.	RECOMMENDATION TO CARDIFF PARKS: Remove deadwood. Carry out further assessment of decay points and take appropriate remedial action to prevent risk of failure.	20-40	A-Bi	8.9	227	
175	94	Copper beech	16	920	8	6.5	4.5	7.5	4	M	Decay bracket developing in between buttress roots. Deadwood of up to 90mm diameter. Fungal brackets at base to north.	RECOMMENDATION TO CARDIFF PARKS: Remove deadwood. Remove deadwood. Carry out decay detection test.	40+	Ai	11.0	360	
176	95	Red oak	14	720	3	5.5	7.5	9	5	M	Exposed surface roots lifting road kerbs. Deadwood of up to 75mm.	RECOMMENDATION TO CARDIFF PARKS: Remove deadwood. Remove deadwood.	40+	Ai	8.6	211	
	96	Cedar	18	920	9.5	8	11	6	3	M	Large pruning wound at 2-6m, reasonable good specimen. Low limbs removed. Occasional broken branches.	Reduce canopy spread to north by 1m.	40+	Ai	11.0	366	27/03/17
14	97	Willow	18	1,010	6	5.5	5.5	10.5	3	LM	Significant lean to NE over river, two-stemmed from 3.0m. Growing on edge of riverbank. Feature tree.	Bat roost assessment required. Remove to construct flood defence.	20-40	A-Bi	12.1	460	
	98	Sweet chestnut	4.5	110	1.5	1.5	1.5	1.5	2	Y	Stake & tie, easily replaced if required. Basal bark damage.	Remove stake and tie.	40+	Ci	1.3	3	
15	99	Thorn	5	225	2	3.5	2	2.5	2.5	EM	Slight lean to south.	Remove to construct flood defence.	10-20	Ci	2.2	15	
16	100	Hornbeam (fastigiata)	13	500	7	5.5	6.5	5	2	M	Reasonable form.	Remove to allow temporary service diversion around bridge	20-40	Bi	6.0	102	
	101	Hornbeam (fastigiata)	13	425	4.5	5.5	6.5	3.5	2.5	M	Reasonable form.		20-40	Bi	5.1	82	
	102	Sycamore	6	280	4	4	4	3	3	EM	Numerous pruning wounds 2.0-3.0m, relatively poor form. Shrimp coloured foliage in spring.		20-40	Ci	3.4	36	
	103	Liquidamber	12	510	4	3.5	4.5	4	2	M	Slight twist in stem to SE over railings. Probably liquidambar orientalis.		20-40	Bi	6.1	117	
	104	Tree of heaven	16.5	1010	6.5	5	5	6	4	M	Slight lean to SE over railings (growing into railings). Large bark wound 1.0-3.0m east side, very long pruning wound 4.0m SE side. Female - could collect seed.		20-40	Bi	12.1	423	
	105	Walnut	8.5	355	6	5	5	5.5	3	EM	Slight lean to NE over railings		20-40	Bi	4.3	58	
<b>Waterloo Gardens:</b>																	
24	106	Birch	10.5	525	6	5	6.5	5	2.5	M	Reasonable form, small amounts of minor deadwood in canopy.	Remove to allow temporary service diversion around bridge	20-40	Bi	6.3	125	

Roath Brook

Tree Works  
BS 5837 Tree Schedule

Tag nos	Tree/Group No.	Species	Height (m)	Stem Diam. at 1.5m (mm)	Branch Spread (m)				Canopy Clearance (m)	Age Class	Observations <b>ADDITIONAL COMMENTS FROM 01-11-2017 VISIT</b>	Required Tree works. <b>Green text: works for implementation by Cardiff Parks. Red text: Revised works</b>	Estimated Remaining Contribution (years)	BS 5837 Category Grading	Protection Distance (m)	Tree Protect. Area (m2)	Date of Change
					N	S	E	W									
21	107	Willow	10	235	5	3	3	3	2	EM	Tight fork with included bark at 2.0m, likely to split apart.	Remove for works.	<10	U	2.8	25	
22	108	Crab apple	6	255	3.5	2	3	2.5	2.5	M	Minor bark wounds at base, numerous pruning wounds, minor deadwood.	Remove for works.	10-20	Ci	3	29	
23	109	Sycamore	10.5	370	3.5	3.5	4.5	3.5	4	M	Clear stem to 3.5m, slightly swept stem, interfering with street light.	Remove for works.	40+	Bi	4.4	62	
26	110	Cherry	5	290	3	2	3	2.5	4	M	Exposed surface roots with minor decay, poor graft union with pruning wounds at 2.0m	Remove.	10-20	Ci	3.5	38	
25	111	Birch	11	425	5	4.5	6	3.5	4	M	Pruning wound with decay pocket at 1.5m	Remove to allow reprofiling of bank. Soft fell in case of bats	20-40	Bi	5.1	82	
27	112	Cherry	6	275	2.5	3	3.5	3	3.5	M	Numerous pruning wounds at 2.5m	Remove for works.	10-20	Ci	3.3	34	
	113	Cherry	6	305	5	6	4	4	3.5	M	Numerous pruning wounds.		10-20	Ci	3.7	42	
	114	Sycamore	6	350	4	4	4	4	2.5	EM	Reasonable form.		40+	Bi	4.2	55	
	115	Cherry	4	265	5	3	2.5	3	2.5	EM	Pruning wounds at 2.0m over road/path.		10-20	Ci	3.2	32	
	116	Laburnum	6	200#	2.5	3	2.5	2.5	2	Y	Ivy on main stem.		10-20	Ci	2.4	18	
	117	Tulip tree	16	780	6	7.5	4	7	5	M	Good specimen tree.		40+	Ai	9.4	275	
	118	Oak	14.5	810	5.5	8	5.5	7	6	M	Three stemmed tree from 3.0m, ivy on main stem.		40+	Ai	9.7	297	
	119	Sycamore	15.5	850	5	9	9	8	2.5	M	Four stemmed tree from 3.5m, ivy on main stem.		40+	Ai	10.2	327	
	120	Dead stump	3.5	820	-	-	-	-	-	-	Dead stump, standing stock, decay brackets, dense ivy.	Remove.	<10	U	9.8	304	
	121	Tulip tree	17	565	3.5	3.5	4	4	2.5	M	Good specimen tree.		40+	Ai	6.8	144	
	122	Turkey oak	18	860	6	9	9.5	7	5	M	Small amounts of moderate/minor deadwood throughout, ivy on main stem.		40+	Ai	10.3	335	
	123	Thorn	5	310	2.5	3	2	2.5	2.5	EM	Reasonably good form, ivy on main stem.		10-20	Ci	3.7	43	
	124	Holly	4	220	2.5	3	2	2.5	2	EM	Significant lean north into adjacent birch, pruned up to 2.5m		10-20	Ci	2.6	22	
	125	Birch	9	240	6	4	3	4	6	EM	Adjacent holly growing into canopy, minor deadwood.		10-20	Ci	2.9	26	
	126	False cypress	7	225	1.5	1.5	1.5	1.5	1	Y			20-40	Cii	2.7	23	
	127	False cypress	6	225	1.5	1.5	1.5	1.5	1	Y			20-40	Cii	2.7	23	
	128	False cypress	8	270	1.5	1.5	1.5	1.5	2	Y			20-40	Cii	3.2	33	
	129	Birch	11	535	5	6	5	6	4	M	Reasonably good form.		20-40	Bi	6.4	130	
	130	Cherry	4	405	2.5	4	3	3	3	M	Large pruning wound at 2.5m north side and 2.0m west side.		10-20	Ci	4.9	74	
	131	Birch	12	290	3	2	3.5	4.5	4	EM			20-40	Cii	3.5	38	
	132	Birch	10.5	330	4	2.5	3	3	4	EM			20-40	Cii	4	49	
	133	Birch	10	185	2	2	2	2	3	Y	Group of 3no. birch, ivy on main stems.	Remove northern tree, which is leaning.	20-40	Cii	2.2	15	
	134	Apple	5	260	2.5	4	4	3.5	3.5	EM	Significant lean to south, large decayed stem wound at 1.0m		10-20	Cii	3.1	31	
	135	Ash	7	170	1.5	1.5	1.5	1.5	4	Y	Kinked stem, slight lean to south-west		20-40	Cii	2	13	
	136	Snake-bark maple	6	300	4.5	1	2	4	3.5	EM	Four stemmed from 2.0m, slight lean to NW.		20-40	Cii	3.6	41	
	137	Katsura	8	365	3	4	4	4	3	EM			20-40	Cii	4.4	60	
	138	Snake-bark maple	6	250	3.5	4	2	3.5	4	EM	Bark split from base to 1.5m		20-40	Cii	3	28	

Tag nos	Tree/ Group No.	Species	Height (m)	Stem Diam. at 1.5m (mm)	Branch Spread (m)				Canopy Cleara nce (m)	Age Class	Observations  ADDITIONAL COMMENTS FROM 01-11-2017 VISIT	Required Tree works. Green text: works for implementation by Cardiff Parks. Red text: Revised works	Estimated Remaining Contribution (years)	BS 5837 Category Grading	Protect ion Distnce (m)	Tree Protect. Area (m2)	Date of Change
					N	S	E	W									
	139	Mulberry	5	110	2	2	2	2	2.5	Y	Stake & tie, easily replaced if required.	Remove tree stake. Remove tree. Replace with an 8-10cm container grown Morus alba 'Platanifolia' in Waterloo Gardens	40+	Ci	1.3	5	27/03/17
46	140	Birch	6	75	1	1	1	1	2.5	Y	Easily replaced if required.	Remove.	10-20	Ci	1	3	
47	141	Red oak	5	135	3	3	3	3	2	Y	Easily replaced if required, stake (no ties).	Remove.	40+	Ci	1.6	8	
	142	Lime	13	560	5.5	5	5.5	4.5	2.5	M	Tight fork at 4.0m. Can retain if contractor is able to work from southern side of the wall. If not possible, tree will need to be removed.	Limit crown lifting to 6m, as shown on the photo in Appx Eiii)	20-40	Bi	6.2	122	27/03/17
	143	Lombardy poplar	22	675	2.5	2.5	2.5	2.5	15	M	Two stemmed from 7.0m		20-40	Ci	8.1	204	
	144	Ash	16	650	4	8.5	8	6	4	M	Occluded pruning wounds at 4.0 & 6.0m. Occasional deadwood less than 125mm.	Remove major deadwood. Reduce the crown spread to the south to a line 1.5m from the wall to enable piling, as shown on the photo in Appx Eii). Carry out 15-20% crown reduction.	40+	Ai	7.4	174	27/03/17
	145	Birch	14	470	4	4.5	3	1.5	4	M	Dense ivy. Low vigour.		10-20	Ci	5.6	100	
	146	Birch	7	215	3	3.5	3.5	1.5	2	EM	Pruning wounds in canopy.		10-20	Ci	2.6	21	
	147	Birch	10	350	4.5	5	2	2	3	EM	Significant lean to east.		10-20	Ci	4.2	55	
48	148	Lime	15	530	8	6.5	7	7	3.5	M		Remove to construct wall	20-40	Bi	6.4	127	
49	149	Lime	14	420	5	3.5	5	5	3.5	M		Remove for works.	20-40	Bi	5	80	
50	150	Lime	13	345	5	5	7	5	4	M		Remove for works.	20-40	Bi	4.1	54	
51	151	Lombardy poplar	23	1,250	2	3	3.5	2	12	M	Three stemmed from 2.0m	Bat roost assessment required. Remove for works.	20-40	Bi	15	707	
	152	Dead stump	5	560	-	-	-	-	-	-	Dead decaying stump.	Remove.	<10	U	6.7	142	
	153	Birch	12.5	300	1	4	5	2	3	M	Twisted stem, numerous witches' broom		20-40	Cii	3.6	41	
	154	Birch	12.5	345	4	2	2	5	3.5	M	Basal decay pocket at 1.0m, exposed surface roots		10-20	Cii	4.1	54	
	155	Birch	14	400	3	4	6	3.5	3	M	Two stemmed from 2.5m		20-40	Cii	4.8	72	
73	156	Fastigate pear	9	210	1.5	1.5	1.5	1.5	4	EM	Tight fork at 2.5m, suckers at base.	Remove to construct path	20-40	Ci	2.5	20	
72	157	Thorn	4	150	2	2	2	2	2.5	EM	Pruning wounds with decay pocket at 2.4m	Remove to construct path	10-20	Ci	1.8	10	
70	158	Grey willow	9	500	4.5	6	5	5	2	M	Large pruning wounds on lower stem with minor decay.	Remove for works. Soft fell in case of bats.	10-20	Ci	6	113	
	159	Felled															



Tag nos	Tree/ Group No.	Species	Height (m)	Stem Diam. at 1.5m (mm)	Branch Spread (m)				Canopy Clearance (m)	Age Class	Observations  ADDITIONAL COMMENTS FROM 01-11-2017 VISIT	Required Tree works. Green text: works for implementation by Cardiff Parks. Red text: Revised works	Estimated Remaining Contribution (years)	BS 5837 Category Grading	Protect ion Distnce (m)	Tree Protect. Area (m2)	Date of Change
					N	S	E	W									
	160	Oak	14	800	8	6.5	5	6.5	3	M	Dense ivy, small amounts of moderate deadwood	Remove 1 broken branch and one further high lateral, branch, both towards south-east to allow piing rig access.	20-40	Bi	9.6	290	27/03/17
	161	Oak	13	640	6	7	7	8	4	M	Ivy on main stem, small amount of minor deadwood.	Reduce crown spread to south by 1m, as shown on the photo in Appx Eii).	40+	Bi	7.7	185	27/03/17
	162	Oak	13	555	6	8.5	8	5	3	M	Small amount of minor deadwood in crown.		40+	Bi	6.7	139	
	163	Oak	13.5	705	7.5	3.5	7	9	3	M	Five stemmed from 3.0m		40+	Bi	8.5	225	
57	164	Weeping willow	2	110	2	2.5	2.5	1.5	1	P	Lean to east, easily replaced if required.	Remove to construct path	10-20	Ci	1.3	5	
56	165	Birch	11	310	5	3	4	3.5	2.5	EM	Leans north towards road.	Remove for works.	20-40	Ci	3.7	43	
55	166	Birch	7	220	3.5	2.5	4	2	2.5	EM	Snapped stem hanging over river (piptoporus bracket), minor deadwood.	Remove for works.	10-20	Ci	2.6	22	
53	167	Birch	12	280	3	3	3	3	4	EM		Remove for works.	20-40	Ci	3.4	35	
52	168	Birch	10	260	4.5	2.5	5	3.5	3	EM		Remove for works.	20-40	Ci	3.1	31	
54	169	Norway maple	9	325	3.5	4	5	3.5	2	EM	On rivers edge at base of slope.	Remove for works.	20-40	Ci	3.9	48	
<b>Railway Gardens:</b>																	
	170	Birch	12.5	415	7	5	3	3	2.5	M	Minor decay pockets in lower stem, interfering with street light.		20-40	Cii	5	78	
	171	Birch	13	255	4	3.5	2.5	2.5	3	EM	Reasonably good form.		20-40	Cii	3	29	
	172	Birch	12	215	2	3.5	2.5	3.5	3	EM	Small amounts of minor deadwood in top of canopy.	Remove hanging branch.	20-40	Cii	2.6	21	
	173	Birch	12	240	2.5	2.5	2.5	4	2.5	EM	Reasonably good form.		20-40	Cii	2.9	26	
74	174	Ash	12.5	400	4.5	3.5	4	5	3	EM	Twin stemmed from 2.0m, concrete pad around base.	Remove for works.	20-40	Ci	4.8	72	
75	175	Birch	11	340	3	3	3	3	2	EM	Group of three birch on top of concrete retaining wall adjacent to river.	Remove for works.	20-40	Cii	4.1	52	
79	176	Lime	7	180	2.5	2.5	3	3	2	Y	Easily replaced if required.	Remove to allow construction access	40+	Ci	2.2	12	
80	177	Poplar	20	740	3	3	3	2	2.5	M	Ivy on main stem. Twin stem from base - tight fork.	Remove to construct new wall.	20-40	Ci	8.9	248	
83	177A	Willow	8	170							Additional Tree added 02-02-2017	Remove	5-15	C2			02/02/17
81	178	Poplar	18	430	3	4	5	4.5	3	M	Leaning to southeast.	Remove to allow lime avenue to develop.	20-40	Ci	5.2	84	
82	179	Lime	5	160	2.5	2.5	2.5	2.5	1.8	Y	Suppressed by poplar, but can develop.	Remove	40+	Bii	1.9	12	
77	G179	Lime	7-9	180-265	3	3	3	3	2.5	Y	Recent lime avenue planting (occasional oak). Group of 26no. trees.	Engineering solution to avoid need to remove one tree adjacent to T417 to allow construction of ramp for bridge.	40+	Cii	3.2	-	
	180	Poplar	13.5	500	4	4	4.5	3.5	2	EM			20-40	Ci	6	113	
	181	Poplar	14	695	3	4	4	4.5	4	EM	Ivy on two stems.		20-40	Ci	8.3	219	
	182	Poplar	13.5	230	3	2.5	3	4	4	EM	Strongly swept stem to south.		20-40	Ci	2.7	24	
	183	Poplar	14.5	625	4.5	4.5	6	6	3	EM	Good form.		20-40	Ci	7.5	177	

Tag nos	Tree/ Group No.	Species	Height (m)	Stem Diam. at 1.5m (mm)	Branch Spread (m)				Canopy Cleara nce (m)	Age Class	Observations  ADDITIONAL COMMENTS FROM 01-11-2017 VISIT	Required Tree works. Green text: works for implementation by Cardiff Parks. Red text: Revised works	Estimated Remaining Contribution (years)	BS 5837 Category Grading	Protect ion Distnce (m)	Tree Protect. Area (m2)	Date of Change
					N	S	E	W									
78	184	Poplar	26.5	970	5	6	8	6	3	M	Shown in photo in Apendx Eiii). Reasonably good form. "Mini-piles" will cause root severance affecting approx 8% of the Root Protection Area. Ground protection will be required for access, but possible to retain-if crown-reduced providing major roots are not severed and condition is reviewed 12 months after completion of works.	Remove to allow construction access. Reduce crown by 25%, as per photo included in Appendix Eiii). Hand dig trench to 0.9m prior to driving piles. Arboricultural consultant to inspect before any roots over 25mm diameter are severed. If major roots severed, tree to be felled, if not, condition to be monitored 12 months after completion of works.	20-40	Bi	11.6	426	10/04/17
	185	Poplar	13	380	2.5	3	4	3.5	3	EM	Bark wound at base, suckers.		10-20	Ci	4.6	65	
	186	Poplar	20	740	8	6	8	6.5	2.5	M	Reasonably good form.		20-40	Bi	8.9	248	
	187	Robinia	14.5	710	5	4.5	3	5	4	M	Twin stemmed from 2.0m, tight forks, stems touching at 3.0m. 02-02-2017: NB: Dieback and fungal decay at base	02-02-2017: Parks to be advised to undertake Tree Hazard Assessment	20-40	Bi	8.5	228	
	188	Ash	12.5	685	4.5	7	7.5	8	2.5	M	Small amount of moderate deadwood in crown. Wall realigned to avoid further crown reduction and to minimise excavation in Root Protection Area.		20-40	Bi	8.2	212	
105	189	Foxglove tree	15	730	3.5	4.5	5	4.5	2	M	Branch ripped out on west side at 10.0m	Remove to construct new wall. Soft fell in case of bats.	20-40	Bi	8.8	241	
103	190	Cherry	9	370	3	4	3	6	5	M	Ivy at base.	Remove.	10-20	Ci	4.4	62	
102	191	Box elder	10	295	0	5	5	1	5	EM	Lean to south, ivy at base.	Remove to allow construction access	10-20	Ci	3.5	39	
101	192	Box elder	11	340	3.5	4	6	4	4	EM	Ivy at base.	Remove for new path.	20-40	Ci	4	52	
99	193	Cherry	8	205	2.5	1.5	3	4	4	EM	Ivy on main stem.	Remove for new path.	10-20	Ci	2.5	19	
100	194	Cherry	3.5	170	2	1	1.5	1.5	2	EM	Crossing, fused branches in canopy, ivy at base.	Remove for new path.	10-20	Ci	2	13	
98	195	Bay	4.5	260	2	2	2	2	2.5	EM	Ivy on stems.	Remove for new path.	10-20	Ci	3.1	30	
	196	Cherry	8	240	3	3.5	4	3	4	EM	Twisted stem.		10-20	Ci	2.9	26	
97	197	Cherry	10	240	3.5	3.5	5	2.5	3.5	EM	Ivy on main stem.	Remove for works.	20-40	Ci	2.9	26	
	198	Bay	4.5	260	4	2	2	2	2	EM	Ivy on stems.		10-20	Ci	3.1	31	
	199	Maple	9	320	5	3	4	3.5	3	EM	Ivy at base. Wall realigned to avoid further crown reduction and to minimise excavation in Root Protection Area.		20-40	Ci	3.8	46	
	200	Maple	10	500	4.5	5	4.5	5.5	4	M	Numerous pruning wounds at 2.0m. Purple foliage.		20-40	Bi	5.8	104	
	201	Whitebeam	9	365	4.5	3.5	4	3	2.5	M	Congested crown at 2.5m, ivy at base.		20-40	Ci	4.4	60	
96	202	Zelkova	10	375	4	4	4	4	4	EM	Tree stemmed from 2.0m, crossing branches.	Remove for works.	20-40	Bi	4.5	64	
95	203	Birch	11	230	2.5	2.5	2.5	2.5	3	EM	Exposed buttress roots, minor root damage.	Remove for works.	20-40	Ci	2.8	24	

Roath Brook

Tree Works  
BS 5837 Tree Schedule

Tag nos	Tree/Group No.	Species	Height (m)	Stem Diam. at 1.5m (mm)	Branch Spread (m)				Canopy Clearance (m)	Age Class	Observations <b>ADDITIONAL COMMENTS FROM 01-11-2017 VISIT</b>	Required Tree works. <b>Green text: works for implementation by Cardiff Parks. Red text: Revised works</b>	Estimated Remaining Contribution (years)	BS 5837 Category Grading	Protection Distance (m)	Tree Protect. Area (m2)	Date of Change
					N	S	E	W									
94	204	Birch	11	370	4	2	3.5	4	3	M	Dense ivy on main stem.	Bat roost assessment required. Remove for works.	20-40	Ci	4.4	62	
91	205	Beech	12	425	5	5	4.5	4.5	3	EM	Ivy at base.	Remove for works.	20-40	Ci	5.1	82	
	206	Willow	15.5	715	7.5	7	8	5	4	M	Minor decay in pruning wound on main stem at 2.5m and missing bark strip to base. Exposed buttress roots with minor decay.	<del>Reduce to 3m in height.</del> Remove	20-40	Bi	8.6	231	27/02/17
84	207	Willow	16	755	7.5	5.5	7	6.5	4	M	Large pruning wound at 2.5m, minor deadwood throughout crown, exposed buttress roots with minor decay pocket.	Remove	20-40	Bi	9	258	
	208	Birch	16	395	2.5	5	5	4.5	5	M			10-20	Ci	4.7	71	
	209	Ash	14	405	3	6	6.5	5.5	5	M	Twin stemmed from 0.5m		20-40	Ci	4.9	74	
	210	Indian bean tree	12	630	6	2	4	3.5	5	M	Large stem removed at 3.0m east side, large branch wound in stem on south side at 1.0-2.0m, unbalanced crown.		10-20	Ci	7.6	180	
	211	Bay	6	400	2	2	2	2	1	Y			10-20	Ci	4.8	72	
	T247	Bay	1.6	200	1	1	1.5	1.5	0.1	Semi-mature	Multiple stems from base - tightly clipped.		10-20	C2	2.4	18	
	T248	Amelanchier	1.5	40	0.8	0.8	0.8	0.8	0.6	Young	Four stems from base - average 20mm. Healthy young shrub - minor bark damage. Foliage yellowing.		20-40	C2	0.5	1	
	T21	Sycamore	17	630	5.5	6	6	3	1.8	Early mature	Growing out of face of riverbank, with all weight over river. Three stems from base - 390, 480 & 140mm. Roots becoming exposed through erosion. Risk of uprooting.	Remove to allow regrading of bank.	15-30	B-C2	7.6	179	
	T249	Ginkgo	17.5	720	7	4	3	5	2.0	Mature	Good form and structure.		>40	A2	8.6	234	
	T250	Yew	10.5	400	4	4	4	4	1.5	Early mature	Good vigour.		>40	A2	4.8	72	
	T251	Beech	17.5	770	9	8	7	9	7.0	Mature	Good form and structure.		>40	A2	9.2	268	
	T252	Beech	17.5	810	5	8	9	5	4.0	Mature	Six stems from 3m. Asymmetric crown, but good vigour.		>40	A-B2	9.7	297	
	T253	Yew	8.5	300	2.5	2.5	2.5	2.5	1.5	Early mature	Moderate vigour.		>40	B2	3.6	41	
	T254	Yew	9	630	3	5	6	2	1.6	Early mature	Twin stem from 1.3m - 400 & 480mm. Asymmetric crown.		>40	B2	7.6	179	
	T255	Holly	6.5	250	2.5	3.5	3	2.5	1.6	Semi-mature	Four stems from base - 90, 110, 120 & 170mm. Good vigour.		15-30	B-C2	3.0	28	
	G256	Yew/Mahonia	3.5 - 5.5	130	0	0	0	0	0.2	Semi-mature	Five yew, with mahonia to west, forming an evergreen block. Yew all multi stem, bushy trees.		20-40	B-C2	1.6	8	
	T257	Indian bean tree	4	190	3	5	2	5	3	Semi-mature	Slight lean to south. Main stem bifurcates at 2m. Bushy structure.		20-40	B2	2.3	16	
	T258	Kentucky coffee tree	12.5	540	6.5	6.5	6.5	6.5	2.5	Early mature	Attractive tree. Buttress roots exposed. Good vigour.		>40	A2	6.5	132	
193	T259	Pear	8.5	410	3.5	3.5	3.5	3.5	1.5	Mature	Attractive tree.	Remove to allow regrading of bank.	15-30	B2	4.9	76	
192	T260	Birch	12.5	300	2.5	4	2	3	2.5	Early mature	Growing on face of riverbank - root system becoming eroded.	Remove to allow regrading of bank.	15-30	B-C2	3.6	41	
191	T261	Ash	12.5	360	4	4	5	4	1.7	Early mature	Growing on face of riverbank, with slight lean over river.	Remove to allow regrading of bank.	20-40	B2	4.3	59	
190	T262	Birch	14	330	3.5	4	5	4.5	1.5	Early mature	Only moderate vigour. Surface roots exposed.	Remove to allow regrading of bank.	15-30	B2	4.0	49	
189	T263	Sycamore	14.5	360	5	2	4	2.5	1.7	Semi-mature	Growing at base of riverbank. Leaning to north.	Remove to allow regrading of bank.	20-40	B2	4.3	59	
188		Mixed saplings	2-5	<75								Remove					01/11/17

Tag nos	Tree/ Group No.	Species	Height (m)	Stem Diam. at 1.5m (mm)	Branch Spread (m)				Canopy Cleara nce (m)	Age Class	Observations  ADDITIONAL COMMENTS FROM 01-11-2017 VISIT	Required Tree works. Green text: works for implementation by Cardiff Parks. Red text: Revised works	Estimated Remaining Contribution (years)	BS 5837 Category Grading	Protect ion Distnce (m)	Tree Protect. Area (m2)	Date of Change
					N	S	E	W									
	T264	Pear ( <i>Pyrus calleryana</i> )	8	200	2	3	3	2	1.7	Semi-mature	Leaning to east.		20-40	B2	2.4	18	
186	T265	Birch ( <i>Betula papyrifera</i> )	10	290	4	4	4	4	1.7	Early mature	Attractive tree. Minor damage to surface roots.	Remove to allow regrading of bank.	20-40	B2	3.5	38	
185	T266	Ash	17.5	650	5	6	9	7	1.9	Mature	Major limb to north removed at 2.5m - decay beginning. Epicormic growth. Occasional deadwood.	Remove to allow regrading of bank. Soft fell in case of bats.	20-40	B2	7.8	191	
184	T267	Alder	17.5	680	4.5	4.5	4.5	4.5	3	Mature	Growing on face of riverbank. Erosion around roots.	Remove to allow regrading of bank. Soft fell in case of bats.	15-30	B2	8.2	209	
183	T268	Birch ( <i>Betula papyrifera</i> )	8.5	250	3.5	4	4	3	1.7	Early mature	Minor basal bark damage.	Remove to allow regrading of bank. NB:NOW TO RETAIN	20-40	B2	3.0	28	01/11/17
182	T269	Rowan	7.5	220	3	3	2	3	1.7	Early mature	Tight forks.	Remove to allow regrading of bank. NB:NOW TO RETAIN	15-30	B-C2	2.6	22	01/11/17
	T270	Cherry	13	490	6	6	6	6	1.6	Mature	Pink flowering. Good vigour. Minor damage to surface roots.		15-30	B2	5.9	109	
180	T271	Oak	12	140	1.5	2.5	4	2	2.5	Semi-mature	Drawn up leaning to east.	Remove to allow regrading of bank.	15-30	C2	1.7	9	
181	T272a	Holly	5	70	2.2	2.2	2.2	2.2	0.1	Semi-mature		Remove to allow regrading of bank.	15-30	C2	0.8	2	
179	T272b	Willow	12.5	400	3.5	3.5	3.5	3.5	1.8	Mature	Six stems from 2m.	Remove to allow regrading of bank.	20-40	B2	4.8	72	
	T273	Laburnum	4	190	2	2	1	2.5	1.5	Mature	Growing out of riverbank and leaning to west.	Remove to allow regrading of bank. ALREADY REMOVED.	10-20	C2	2.3	16	01/11/17
	T274	Dead tree	2.5	130	1	1	1	1	1.5	Early mature		Remove. ALREADY REMOVED.	<10	U	1.6	8	01/11/17
178	T275	Oak	7.5	160	1.5	1.5	1.5	1.5	1.7	Semi-mature	Twin stems, growing from old stump - 90 & 130mm.	Remove to allow regrading of bank.	10-20	C2	1.9	12	
	T276	Magnolia grandiflora	3	80	1.5	1.5	1.5	1.5	1.7	Young	Bark missing from 75% of trunk. Memorial tree.		10-20	C2	1.0	3	
	T277	Dead tree	6	170	2	2	2	2	1.8	Semi-mature	Dead.	Remove and replant. ALREADY REMOVED	<10	U	2.0	13	01/11/17
	T278	Hackberry	3.5	110	1.5	2	2.5	1	1.6	Semi-mature	Slight lean to east.		20-40	C2	1.3	5	
	T279	Crab apple	5.5	310	4	4	4	4	2.5	Mature	Moderate vigour.		15-30	B-C2	3.7	43	
	T280	Ash	7.5	230	3	3	3	3	1.8	Semi-mature	Reasonable form and structure. Memorial tree. Bark wound at 1.2m to north.		15-30	B-C2	2.8	24	
	T281	Cedar	18	1070	8	8	8	8	1.7	Mature	Occasional branches broken/removed. Good vigour.		>40	A2	12.8	518	
	T282	Cockspur thorn	5	170	3	1	3	1	1.5	Semi-mature	Slight lean to north.		15-30	B-C2	2.0	13	
	T283	Ironwood	2.5	70	0.6	0.6	0.6	0.6	1.5	Young	Memorial tree. Only moderate vigour. Bark damage.		15-30	C2	0.8	2	
	T284	Tree of heaven	8	260	4	4	4	4	3	Semi-mature	Main stem bifurcates at 2.5m.		20-40	B2	3.1	31	
	T285	Magnolia	7	540	1.5	8	1.5	4	1.6	Mature	Four stems at 1.5m - average 270mm. Attractive wide spreading tree.		15-30	B2	6.5	132	
	T286	Magnolia	7	340	2	6.5	5	1	2	Mature	Growing as a pair with T285.		15-30	B2	4.1	52	
	G287	5 No. Turkey oak	18	650 - 780	0	0	0	0	4	Early mature	Growing as a group. High amenity value.		>40	A2	9.4	275	
	T288	Holly	6	180	3	3	3	3	1	Early mature	Twin stem from base - 100 & 150mm. Good vigour.		15-30	B-C2	2.2	15	
	T289	Ginkgo	15.5	780	3.5	3.5	3.5	3.5	1.7	Mature	Multiple stems from 3m.		20-40	B2	9.4	275	
	G290	Evergreen shrubs	3.5 - 6.5	90	0	0	0	0	0.1	Mature			10-20	C2	1.1	4	

Tag nos	Tree/ Group No.	Species	Height (m)	Stem Diam. at 1.5m (mm)	Branch Spread (m)				Canopy Clearance (m)	Age Class	Observations  <b>ADDITIONAL COMMENTS FROM 01-11-2017 VISIT</b>	Required Tree works. <b>Green</b> text: works for implementation by Cardiff Parks. <b>Red text: Revised</b> works	Estimated Remaining Contribution (years)	BS 5837 Category Grading	Protect ion Distnce (m)	Tree Protect. Area (m2)	Date of Change
					N	S	E	W									
T291	Cherry	8.5	290	4	2.5	2.5	4	2.5	Mature	Poorly developed crown.		10-20	C2	3.5	38		
T292	Apple	10.5	390	5	5	5	5	3.5	Mature	Bark wounds.		15-30	B-C2	4.7	69		
T293	Holly	5.5	360	3	3	3	3	0.5	Mature	Ivy, but good vigour.		15-30	B-C2	4.3	59		
T294	Bay	8	240	2	2	2	2	1.5	Early mature	Twin stem from base - 150 & 190mm.		10-20	C2	2.9	26		
T295	Cotoneaster	2	160	1	1	1	1	0.1	Mature	Weeping variety.		10-20	C2	1.9	12		
T296	Cherry	5	190	3	3	3	3	1.5	Early mature	Sway stemmed at base.		15-30	B-C2	2.3	16		
T297	Cherry	9	580	5	4	3	6	3.5	Mature	Dying back. Almost entirely dead.	Remove and replant. <b>ALREADY REMOVED</b>	<10	U	7.0	152	01/11/17	
T298	Cherry	9	550	3	6	7	5	1.8	Mature	Attractive, wide spreading ornamental variety. Occasional decay pockets.		15-30	B2	6.6	137		
T299	Holly	5	110	1.5	1.5	1.5	1.5	1.2	Semi- mature	Good form and structure.		20-40	C2	1.3	5		
G300	Cotoneaster	3.5 - 6	120 - 350	0	0	0	0	1	Mature			10-20	C2	4.2	55		
T301	Cherry	7.5	300	1	7	3.5	3.5	1.7	Mature	Ornamental variety. Vigour beginning to decline.		10-20	C2	3.6	41		
T302	Red oak	18	1160	11	12	9	11	6	Mature	Fine wide spreading tree. Fungal decay at base. Broken branch (70mm diameter) hanging over road. Epicormic growth.	Internal decay detection test to gauge extent of hollowing. <b>RECOMMENDATION TO CARDIFF PARKS: REMOVE DEADWOOD AND CARRY OUT A NON INVASIVE, "PICUS" INTERNAL DECAY TEST. Remove hanging branch. BRANCH ALREADY REMOVED</b>	20-40	B2	13.9	608	23/11/17	
T303	Elm	12.5	440	3.5	3.5	3.5	3.5	2	Early mature	Fastigate form. Good crown shape.		20-40	B2	5.3	88		
T304	Plane	7.5	170	3	3	3	3	1.8	Semi- mature	Good form and structure.		>40	A-B2	2.0	13		
T305	Oak	18	850	10.5	10.5	10.5	10.5	1.8	Mature	Wide spreading feature tree. Deadwood of up to 140mm.		>40	A2	10.2	327		
T306a	Acer cappadocicum	17	940	9	9	9	9	1.8	Mature	Wide spreading feature tree. Exposed buttress rooting.		>40	A2	11.3	400		
T306b	Young tree	4	80	2	2	2	2	1.3	Young	Good quality young tree.	Adjust tree stake.	>40	C2	1.0	3		
T307	Nettle tree	3	70	1.5	1.5	1.5	1.5	1.8	Young	Moderate vigour.		20-40	C2	0.8	2		
T308	Crab apple	4.5	160	3.5	3.5	3.5	3.5	1.8	Mature	Decay beginning to main stem.		10-20	C2	1.9	12		
T309	Norway maple	18	970	4	9	12	10	2	Mature	Leaning to east, but crown reasonably well balanced. Bracket fungi around base.	<b>RECOMMENDATION TO CARDIFF PARKS: NON INVASIVE, "PICUS" INTERNAL DECAY TEST</b>	20-40	B2	11.6	425	23/11/17	
T310	Norway maple	18	850	7	7	12	11	1.7	Mature	Resin spots to main stem.		20-40	B2	10.2	327		
T311	Norway maple	18	970	12	5	11	9	2.7	Mature	Leaning to northeast. Rootplate becoming eroded. Resin spots around base. Minor deadwood. <b>GANNODERMA FUNGAL BRACKETS AT BASE.</b>	<b>RECOMMENDATION TO CARDIFF PARKS: NON INVASIVE, "PICUS" INTERNAL DECAY TEST</b>	20-40	B2	11.6	425	23/11/17	
T312	Tulip tree	10	280	3	4	4	3	1.8	Semi- mature	Tight forks.		20-40	B2	3.4	35		
T313	Tulip tree	6	180	3	3	3	3	1.9	Semi- mature	Good form and structure. Memorial tree.		>40	A-B2	2.2	15		
T314	Red oak	9	350	4.5	4.5	4.5	4.5	1.7	Semi- mature	Good form and structure.		>40	A-B2	4.2	55		
T315	Liquidambar	4	130	2	2	2	2	2.5	Semi- mature	Good form and structure.		20-40	B2	1.6	8		

Tag nos	Tree/ Group No.	Species	Height (m)	Stem Diam. at 1.5m (mm)	Branch Spread (m)				Canopy Clearance (m)	Age Class	Observations  ADDITIONAL COMMENTS FROM 01-11-2017 VISIT	Required Tree works. Green text: works for implementation by Cardiff Parks. Red text: Revised works	Estimated Remaining Contribution (years)	BS 5837 Category Grading	Protect ion Distnce (m)	Tree Protect. Area (m2)	Date of Change
					N	S	E	W									
	T316	Rowan	4	90	1.5	1.5	1.5	1.5	2	Semi-mature	Memorial tree. Reasonable form and structure.		15-30	C2	1.1	4	
	T317	Holly	8	240	2	4	1.5	3.5	1.8	Early mature	Twin stem from 0.6m - 140 & 190mm.		15-30	B-C2	2.9	26	
	T318	Thorn	6	210	2.5	2	2	2	1.7	Mature	Slight lean to north. Growing up into crown of T320.		15-30	B-C2	2.5	20	
	T319	Turkey oak	18	700	8	9	8	5	1.8	Early mature	Good form and structure. Low limb removed to southwest - possible decay.		>40	A2	8.4	222	
	T320	Turkey oak	17.5	650	4	9	8	5.5	1.8	Early mature	Minor deadwood.		>40	A-B2	7.8	191	
	T321	Tulip tree	18	1010	11	9	9	12	1.8	Mature	Fine, wide spreading feature tree. Minor deadwood.		20-40	A2	12.1	461	
20	T322	Lime	12.5	390	5	5	5	5	1.6	Semi-mature	Four stems from 2m - tight forks.	Remove: Now to be retained, using No-Dig construction/Hand digging for new path	20-40	B2	4.7	69	17/02/17
19	T323	Lime	6	230	3.5	3.5	3.5	3.5	1.7	Semi-mature	Basal bark damage, with some underlying minor decay.	Remove to create new path.	15-30	B-C2	2.8	24	
	T324	Red oak	4.5	100	2	2	2	2	1.6	Young	Memorial tree. Good form and structure.		>40	C2	1.2	5	
17	T325	Paulownia	9	450	5	5	5	5	3	Early mature	Minor deadwood. Only moderate vigour.	Remove to construct flood defence.	15-30	B2	5.4	92	
18	T326	Mulberry	4.5	100	3	2.5	3.5	3.5	2	Young	Extensive basal bark damage.	Remove to construct flood defence.	15-30	C2	1.2	5	
	T327	Zelkova	8.5	300	3	3	3	3	2.5	Early mature	Tight crown structure. Extensive crown dieback.		10-20	C2	3.6	41	
	T328	Medlar	3.5	70	1.3	1.3	1.3	1.3	1.6	Young		Adjust/remove tree tie.	20-40	C2	0.8	2	
	T329	Cherry	6	200	4.5	3	4	4	1.6	Mature	Attractive ornamental variety.		15-30	B2	2.4	18	
	T330	Foxglove tree	13	540	5	5	5	5	2	Early mature	Minor deadwood, but reasonable vigour.		20-40	B2	6.5	132	
	T331	Maple	9	560	3	3	4	2.5	3	Mature	Vigour declining.		10-20	B2	6.7	142	
	T332	Ash	18	950	9	11	13	7	2.3	Mature	Growing at top of riverbank. Unusual variety - possibly 'Veltheimii'. Minor deadwood.		20-40	A-B2	11.4	408	
	T333	Alder	18	850	6	6	6	6	3.0	Mature	Minor deadwood. Leaning to east.		20-40	B2	10.2	327	
	T334	Lime	14.5	430	6	6	6	6	1.8	Early mature	Slight lean to south. Erosion around rootplate.		15-30	B2	5.2	84	
	T335	Pterocarya	16	610	7	5	8	3.5	1.8	Mature	Leaning to southeast, over river. <i>Inonotus hispidus</i> brackets to main stem. Erosion of rootplate.		10-20	C2	7.3	168	
	T336	Pterocarya	16.5	1060	11	8	9	9	2.0	Mature	Somewhat congested crown. Epicormic growth. Extensive suckering.		>40	A-B2	12.7	508	
	T337	Nettle tree	3.5	80	0.5	0.5	0.5	0.5	1.6	Young	Moderate vigour. Throttle by tree tie. Basal wound.	Remove stake and tie.	20-40	C2	1.0	3	
	T338	Horse chestnut ( <i>Aesculus carnea</i> )	7	340	4	4	4	4	1.5	Early mature	Attractive tree.		20-40	B2	4.1	52	
13	T339	Birch	10.5	est 380	4	4	4	4	1.5	Mature	Acute lean over river from face of bank. Dense ivy.	Remove for works. Soft fell in case of bats.	10-20	B-C2	4.6	65	
12	T340	Young tree	4	50	1	1	1	1	1.5	Young	Memorial tree. Extensive bark wounds to stem. Crown dieback. Yellowing foliage. Herbicide applied around base.	Remove.	<10	U	0.6	1	
11	T341	Lombardy poplar	15.5	560	2	2	3.5	1	3	Early mature	Slight lean to northeast.	Remove for works.	15-30	B-C2	6.7	142	
10	T342	Birch	11	440	4	4	3	3	1.7	Mature	Twin stem from 0.4m - 280 & 340mm. Dense ivy.	Remove for works. Soft fell in case of bats.	15-30	B-C2	5.3	88	
9	T343	Alder	9.5	480	4	7	5	5	1.8	Early mature	Wide spreading tree, growing on mound.	Remove for works.	15-30	B-C2	5.8	104	
	T344	Birch	9.5	200	1	3	3	3	1.4	Early mature	Growing from face of bank, leaning to south.		10-20	C2	2.4	18	

Tag nos	Tree/ Group No.	Species	Height (m)	Stem Diam. at 1.5m (mm)	Branch Spread (m)				Canopy Cleara nce (m)	Age Class	Observations  ADDITIONAL COMMENTS FROM 01-11-2017 VISIT	Required Tree works. Green text: works for implementation by Cardiff Parks. Red text: Revised works	Estimated Remaining Contribution (years)	BS 5837 Category Grading	Protect ion Distnce (m)	Tree Protect. Area (m2)	Date of Change
					N	S	E	W									
177	G345	Birch	9 - 10.5	150 - 280	0	0	0	0	1.3	Early mature	Seven trees - all low quality, one dead.	Remove dead tree. <b>NOT REQUIRED</b>	5-15	C2	3.4	35	23/11/17
	T346	Birch	11.5	400	3	4	2.5	2.5	2.0	Mature	Dense ivy. Moderate vigour.	Remove section of ivy from base.	15-30	B-C2	4.8	72	
	T347	Alder	15.5	780	3	8	8.5	6	2.0	Mature	Four stems at 1.5m - 230, 310, 430 & 520mm. Growing just above stream level. Attractive tree. Ivy to mid crown.	Remove section of ivy from base.	15-30	B2	9.4	275	
	T348	Thorn	7	330	2.5	3.5	3	4	0.8	Mature	Three stems from base - 150, 200 & 210mm. Reasonable vigour. Ivy to lower crown.	Remove section of ivy from base.	15-30	B-C2	4.0	49	
	T349	Alder	7	170	2	2	2	2	1.8	Semi-mature	Good form and structure. Good vitality.		>40	B2	2.0	13	
	T350	Cherry	6	170	3.5	2	3	1	2.5	Early mature	Asymmetric crown, but attractive. Basal bark damage.		15-30	B2	2.0	13	
	T351	Crab apple	9.5	590	6	4.5	7	4.5	1.6	Mature	<i>Ganoderma</i> fungal brackets at base. Extensive crown dieback to north. Deadwood over path and pavement. Ivy over stem union.	Remove to prevent risk from future failure. <b>ALREADY REMOVED.</b>	<10	U	7.1	157	01/11/17
	T352	Ginkgo	2	25	0.4	0.4	0.4	0.4	1.5	Young	Extensive basal bark damage.	Remove stake and tie.	5-15	C2	0.3	0	
	T353	Birch ( <i>Betula papyrifera</i> )	7	160	2.5	2.5	2.5	2.5	2	Semi-mature	Attractive memorial tree.		20-40	B2	1.9	12	
	T354	Cherry	7	160	4	4	4	4	1.7	Semi-mature	Prolific double pink flowers. Memorial tree.		15-30	B2	1.9	12	
	T355a	Fastigiate hornbeam	8	170	2	2	2	2	2	Semi-mature			>40	B2	2.0	13	
	T355b	Dove tree ( <i>Davidia involucrata</i> )	4	80	1.5	1.5	1.5	1.5	2	Young	Damage from tree stake, but good vigour. Memorial tree.	Remove tree stake.	20-40	C2	1.0	3	
	T356	Thorn	6	240	3	3	3	3	1.8	Mature	Good form and vigour.		15-30	B2	2.9	26	
	T357	Thorn	2.5	25	0.5	0.5	0.5	0.5	1.6	Young	Memorial tree.		20-40	C2	0.3	0	
	T358	Cherry	4	250	1.5	3	3	3	1.6	Mature	Double white flowers.		15-30	B2	3.0	28	
	T359	Dove tree ( <i>Davidia involucrata</i> )	5	200	3	3	3	3	1.8	Semi-mature	Good quality attractive tree.		>40	A-B2	2.4	18	
	T360	Magnolia	3.5	160	2	4	3	2.5	1.6	Early mature	Twin stem from base - 100 & 120mm. Memorial tree.		15-30	B2	1.9	12	
	T361	Cherry	3	70	1	1	1	1	1.6	Young	Moderate vigour. Bark damage.		10-20	C2	0.8	2	
	T362	Cherry	5	80	3	3	3	3	2	Semi-mature	Open crown structure. Small white flowers.		15-30	C2	1.0	3	
	T363	Cherry	3.5	210	2	2	3	2	1.6	Mature	Heavily pruned. Decay points. Double white flowers.		10-20	C2	2.5	20	
	T364	Birch ( <i>Betula papyrifera</i> )	8	320	5	5	5	5	1.6	Early mature	Attractive tree.		20-40	B2	3.8	46	
	T365	Robinia	9.5	290	4	5	5.5	2.5	3	Semi-mature	Minor dieback throughout crown.		15-30	B-C2	3.5	38	
34	T366	Cherry	4.5	160	3	3	2	4.5	1.7	Mature	Minor dieback. Double white flowers.	Remove for new path.	10-20	B-C2	1.9	12	
	T367	Cherry	6	520	5	7	5	6	1.9	Mature	Pink flowers. Surface roots decayed. Decay beginning to main stem.		10-20	B-C2	6.2	122	
	T368	Cherry	6	180	4	4	3	4	2	Mature	Profuse small white flowers. Decay to stem.		10-20	B-C2	2.2	15	
29	T369	Magnolia	2.5	25	1	1	1	1	1	Young	Memorial tree. Basal bark damage.	Remove for new path.	10-20	C2	0.3	0	
28	T370	Magnolia	3	60	1.6	1.6	1.6	1.6	1.7	Young	Memorial tree.	Remove.	20-40	C2	0.7	2	
30	T371	Cherry	3	25	0.5	0.5	0.5	0.5	1.8	Young	Delicate white flowers.	Remove.	15-30	C2	0.3	0	
31	T372	Birch	14.5	360	7	2	6	3	2.4	Mature	Leaning to north over river. Minor deadwood.	Remove to widen river.	15-30	B-C2	4.3	59	
32	T373	Sycamore	15	530	5	6	6	7	3	Early mature	Good form and structure.	Remove to widen river.	>40	A2	6.4	127	
33	T374	Norway maple	16	670	8	8	9	5	2	Mature	Minor deadwood, but good vigour.	Remove to widen river.	>40	A2	8.0	203	
35	T375	Birch	11	300	3	5	4.5	4.5	1.5	Mature	Vigour beginning to decline.	Remove.	10-20	C2	3.6	41	
39	T376	Birch	11	380	6	6	6	4	1.5	Mature	Vigour beginning to decline.	Remove for new landscape feature.	10-20	C2	4.6	65	

Tag nos	Tree/Group No.	Species	Height (m)	Stem Diam. at 1.5m (mm)	Branch Spread (m)				Canopy Clearance (m)	Age Class	Observations <b>ADDITIONAL COMMENTS FROM 01-11-2017 VISIT</b>	Required Tree works. <b>Green text: works for implementation by Cardiff Parks. Red text: Revised works</b>	Estimated Remaining Contribution (years)	BS 5837 Category Grading	Protection Distnce (m)	Tree Protect. Area (m2)	Date of Change
					N	S	E	W									
40	T377	Acer griseum	10	380	2	6	5	2	1.8	Early mature	Attractive bronze bark.	Remove for new landscape feature.	15-30	B2	4.6	65	
	T378	Cherry	6	360	5	5	5	5	1.8	Mature	Decay pockets. Double white flowers.		10-20	B-C2	4.3	59	
	T379	Cherry	4	490	2	4	3.5	4	1.8	Mature	Pockets of decay. Pink flowers.		10-20	B-C2	5.9	109	
37	T380	Cherry	5	300	4	4	4	4	1.8	Mature		Remove for new landscape feature.	15-30	B-C2	3.6	41	
38	T381	Thorn	5	260	4	4	4.5	2.5	1.8	Mature	Good form and structure.	Remove for new landscape feature.	15-30	B2	3.1	31	
36	T382	Snake bark maple	3.5	70	1.1	1.1	1.1	1.1	1.5	Young	Memorial tree. Bark damage. Snapped branches. Poor condition.	Remove for new landscape feature.	<10	U	0.8	2	
	T383	Walnut	10.5	400	6	7	6	7	1.8	Early mature	Good form and structure. Damage to surface roots. Flood defence will result in excavation in approx 20% of Root Protection Area. <b>Wall realigned to avoid further crown reduction and to minimise excavation in Root Protection Area.</b>	Remove low secondary branch over footpath to east, leaving 150mm scar. Remove tertiary branch at 3.5m to north, over line of new path, leaving a branch scar of 100mm.	>40	A-B2	4.8	72	
63	T384	Thorn	6	210	3	3	4	3.5	2	Mature		Remove to construct new path	15-30	B-C2	2.5	20	
61	T385	Thorn	6	160	2	3	2	3	2	Mature		Remove	15-30	B-C2	1.9	12	
62	T385A	Sycamore	6		2	2	2	2			Tree added 02-02-2017. Twin stem	Remove		C2			02/02/17
64	T385B	Sapling	2		0.5	0.5	0.5	0.5			Tree added 02-02-2017. Twin stem	Remove		C2			02/02/17
	T386a	Cotoneaster	3	160	4	1.5	2	2	1.5	Mature	Twin stem from base - 100 & 130mm.	Remove.	10-20	C2	1.9	12	
	T386b	Birch	10	290	3	3	3	3	2.8	Mature	Declining vigour.	Remove.	10-20	C2	3.5	38	
	T387	Magnolia	3.5	100	2	2	2	2	1.9	Semi-mature			15-30	C2	1.2	5	
60	T388	Magnolia	5	160	3	2	3	2	1.6	Semi-mature	Twin stem from 0.5m - 110 & 120mm. Attractive tree.	Remove to construct new path	15-30	B2	1.9	12	
59	T389	Magnolia	5	200	3.5	2	5	0.5	1.6	Semi-mature	Leaning to east.	Remove	15-30	B2	2.4	18	
	T390	Lime	16.5	740	6	6	6	6	1.7	Mature	Minor deadwood, but good form and structure. <b>Wall realigned to avoid further crown reduction and to minimise excavation in Root Protection Area.</b>		>40	A2	8.9	248	
	T391	Willow	17	760	8	6	6	6	1.6	Mature	Twin stem from base - 520 & 560mm - third stem removed at 2m. Would require reduction in next three to five years.	Pollard main two stems to 2m in height.	15-30	B2	9.1	261	
58	T392	Birch	11.5	430	4	7	6	4	2	Mature	Declining vigour, but an attractive tree.	Remove	10-20	B-C2	5.2	84	
	T393	Birch	7	140	2.5	2.5	2.5	2.5	1.8	Semi-mature	Memorial tree. Attractive. Why remove?		20-40	B2	1.7	9	
	T394	Liquidambar	3.5	70	0.5	0.5	0.5	0.5	1.6	Young	Good quality, memorial tree.		>40	C2	0.8	2	
	T395	Gleditsia	5	120	2.5	2.5	2.5	2.5	2	Semi-mature			15-30	B-C2	1.4	7	
	T396	Box Elder	7	180	3	4	4	4	2.5	Semi-mature	Good form and structure. Memorial tree.		>40	B2	2.2	15	
41	T397	Cherry	9	380	5	6	6	6	1.8	Mature	Large surface roots. Pink flowers.	Remove for new landscape feature.	15-30	B2	4.6	65	



Roath Brook

Tree Works  
BS 5837 Tree Schedule

Tag nos	Tree/Group No.	Species	Height (m)	Stem Diam. at 1.5m (mm)	Branch Spread (m)				Canopy Clearance (m)	Age Class	Observations <b>ADDITIONAL COMMENTS FROM 01-11-2017 VISIT</b>	Required Tree works. <b>Green text: works for implementation by Cardiff Parks. Red text: Revised works</b>	Estimated Remaining Contribution (years)	BS 5837 Category Grading	Protection Distnce (m)	Tree Protect. Area (m2)	Date of Change
					N	S	E	W									
	T398	Cedar	7.5	260	2.5	2.5	2.5	2.5	1.8	Semi-mature	Bent stem, but good vigour.	Tie back branches to provide clearance for piling rig. If not possible, carry minimum pruning necessary.	>40	B2	3.1	31	27/03/17
	T399	Oak	20	900	8	13	9	11	1.7	Mature	Fine mature tree. Deadwood of up to 140mm. Should be retained, even though flood defence will result in excavation affecting approx 15% of Root Protection Area (hand digging specified) and significant pruning of the canopy. Piles have been replaced with a RC wall, where possible, to minimise crown pruning required.	Reduce crown spread to south by up to 1m, by pruning back small branches, if essential, to facilitate works. Tie back branches instead, if possible. Carry out minimal crown lifting to west, as shown on the photo included in Appendix Ei).	>40	A2-3	10.8	366	10/04/17
42	T400	Cotoneaster	7	220	3	6	4	4	1.7	Early mature	Small growing evergreen. Leaning.	Remove to allow relandscaping	10-20	C2	2.6	22	
43	T401	Sycamore	16	380	2	8	4	4	1.6	Early mature	Growing around concrete barrier.	Remove to allow relandscaping	15-30	B-C2	4.6	65	
44	T402	Birch	14	520	3	5	5	3	1.6	Mature	Dense ivy. Dying back.	Bat root assessment required. Remove to allow relandscaping	10-20	C2	6.2	122	
43	T403	Cherry	5	110	2.5	2.5	2.5	2.5	2	Semi-mature	Good form and structure.	Remove to allow relandscaping	20-40	B-C2	1.3	5	
65	T404	Rowan	7	240	4	1.5	3	3	2	Early mature	Extensive decay to main stem.	Remove	<10	U	2.9	26	
66	T405	Oak	20	730	6	7	6	8	3	Mature	Major limb to north removed from 6m. Minor deadwood.	Remove to widen river. NB: PROVIDE 8no 1200mm LENGTHS FOR SCUPTURE	>40	A2	8.8	241	
	T406	Red oak	18	710	11	8	8	9	3	Early mature	Slight lean to north. Deadwood of up to 120mm, but good vigour. Extensive surface rooting to north.	Remove secondary branches to northwest from main limb to provide 5m crown clearance for working space. Reduce major secondary branch, as shown on the photo in Appx Eii).	>40	A2	8.5	228	27/03/17
67	T407	Birch	17	440	7	6	6	2	1.8	Mature	Leaning to north. Deadwood of up to 120mm. Decay to surface roots.	Remove	10-20	C2	5.3	88	
68	T408	Norway maple	17	510	7	7	3	7	1.8	Early mature	Twin leaders from 3.5m.	Remove to allow regrading of bank	20-40	B2	6.1	118	
69	T409	Red oak	17	820	13	6	11	6	3	Mature	Bark damage at basal buttress.	Remove to allow regrading of bank	>40	A2	9.8	304	
	T410	Cherry	4	80	1	1	1	1	1.9	Semi-mature	Good quality street tree.		20-40	C2	1.0	3	
	T411	Whitebeam	13	550	4.5	6	3	5	1.7	Mature	Good form and structure, but becoming suppressed by T412.		20-40	B2	6.6	137	
	T412	Weeping willow	17	920	9	8	7	9	1.2	Mature	Main stem bifurcates at 3m. Decay entering through pruning wounds. Occasional deadwood.		15-30	C2	11.0	383	
	T413	Lime	14	560	5	5	5	5	1.4	Early mature	Congested crown.	Crown clean.	20-40	B2	6.7	142	
	T414	Birch	11	390	4	4	4	4	1.6	Early mature	Good form and structure.		20-40	B2	4.7	69	
	T415	Birch	11.5	370	4	2.5	4	3	1.6	Early mature	Slight lean to southeast, but an attractive tree.		20-40	B2	4.4	62	

Tag nos	Tree/Group No.	Species	Height (m)	Stem Diam. at 1.5m (mm)	Branch Spread (m)				Canopy Clearance (m)	Age Class	Observations <b>ADDITIONAL COMMENTS FROM 01-11-2017 VISIT</b>	Required Tree works. <b>Green text: works for implementation by Cardiff Parks. Red text: Revised works</b>	Estimated Remaining Contribution (years)	BS 5837 Category Grading	Protection Distnce (m)	Tree Protect. Area (m2)	Date of Change	
					N	S	E	W										
76	T416	Birch	6.5	110	1.5	1.5	1.5	1.5	1.5	Semi-mature	Dead.	Remove.	<10	U	1.3	5		
	T417	Cherry	4	100	1.3	1.3	1.3	1.3	1.8	Semi-mature	Bark wounds.	Adjust stake.	20-40	C2	1.2	5		
	T418	Bay	5	160	2.5	2.5	2.5	2.5	0.3	Early mature	Approx ten stems from base - average 50mm. Good vigour.		15-30	B-C2	1.9	12		
	G419	Beech	11	120 - 200						1.7	Semi-mature	Overgrown beech hedge. Trees at approx 0.3m spacing. Drawn up.	Remove to open up east end of park. NB: RETAIN AS AGREED 02-02-2017	10-20	C2	2.4	18	02/02/17
561 106 104	G420	Understorey	3 - 5	50 - 180						0.3	Semi-mature	Remnants of beech hedge, with occasional holly, bay and maple. No trees of any individual merit.	Remove to open up east end of park. REMOVE GROUPS AS AGREED 02-02-2017 (tag nos: 106 and 556), holly (tag no 104) and 2no low quality beech.	10-20	C2	2.2	15	02/02/17
	T421	Willow	21	940	12	13	9	9	1.5	Mature	Occasional broken branches and deadwood, but showing good vigour.		20-40	B2	11.3	400		
	T422	Willow	18	680	6.5	6.5	6.5	6.5	1.6	Mature	Eight stems from 0.6m - average 240mm - tight forks - future breakout likely.	RECOMMENDATION TO CARDIFF PARKS: 25% crown reduction.	15-30	B-C2	8.2	209	23/11/17	
93	T423	Willow	14	340	3	6	4	4	1.5	Early mature	Eight stems from 2m.	Remove for works.	15-30	B-C2	4.1	52		
91	T424	Birch	14.5	450	5	5	5	5	1.2	Mature	Attractive tree. Broken branches.	Remove for works.	20-40	B2	5.4	92		
89	T425	Pear ( <i>Pyrus calleryana</i> )	6	100	1.2	1.2	1.2	1.2	1.7	Semi-mature	Good form and structure.	Remove for works.	>40	C2	1.2	5		
88	T426	Beech	16	560	6	7	6	6	1.8	Early mature	Good form and structure. Attractive tree. Erosion exposing rootplate.	Remove for works.	>40	A2	6.7	142		
87	T427	Willow	9	130	1	1	1	1	2	Semi-mature	Drawn up. Low quality.	Remove for works.	10-20	C2	1.6	8		
86	T428	Willow	4	180	3	1	2.5	2	1.4	Semi-mature	Only moderate vigour.	Remove for works.	10-20	C2	2.2	15		
85	T429	Pear ( <i>Pyrus calleryana</i> )	4	70	0.5	0.5	0.5	0.5	1.7	Semi-mature	Tree stake rubbing.	Remove for works.	>40	C2	0.8	2		
	G429	Elm	5	90						0.5	Semi-mature	Low quality regrowth: 2 trees - 1 dead.	Remove for works.	10-20	C2	0.8	2	27/03/17
71	G430	Willow	11.5	100 - 160	2	4	5	5	1.8	Semi-mature	Four stems growing from river bank.	Fell.	10-20	C2	1.9	12		
90	T431	Pittosporum	7	370	3.5	3.5	3.5	3.5	1.5	Mature	Seven stems from base - average 140mm. Beginning to decline.	Remove for works.	10-20	C2	4.4	62		
	T432	Damson	6	150	4	1	3	3	1.7	Mature	Bark damage around base.		10-20	C2	1.8	10		

BS 5837:2012, Table 1 Cascade chart for tree quality assessment

Category and definition	Criteria (including subcategories where appropriate)	Identification on plan
<b>Trees unsuitable for retention (see Note)</b>		
<b>Category U</b>	<ul style="list-style-type: none"> <li>Trees that have a serious, irremediable, structural defect, such that their early loss is expected due to collapse, including those that will become unviable after removal of other category U trees (e.g. where, for whatever reason, the loss of companion shelter cannot be mitigated by pruning)</li> <li>Trees that are dead or are showing signs of significant, immediate, and irreversible overall decline</li> <li>Trees infected with pathogens of significance to the health and/or safety of other trees nearby, or very low quality trees suppressing adjacent trees of better quality</li> </ul>	See Table 2
<p>Those in such a condition that they cannot realistically be retained as living trees in the context of the current land use for longer than 10 years</p> <p><i>NOTE Category U trees can have existing or potential conservation value which it might be desirable to preserve; see 4.5.7.</i></p>		
<p><b>1 Mainly arboricultural qualities</b>      <b>2 Mainly landscape qualities</b>      <b>3 Mainly cultural values, including conservation</b></p>		
<b>Trees to be considered for retention</b>		
<b>Category A</b>	Trees that are particularly good examples of their species, especially if rare or unusual; or those that are essential components of groups or formal or semi-formal arboricultural features (e.g. the dominant and/or principal trees within an avenue)	See Table 2
<b>Trees of high quality</b> with an estimated remaining life expectancy of at least 40 years	Trees, groups or woodlands of particular visual importance as arboricultural and/or landscape features	Trees, groups or woodlands of significant conservation, historical, commemorative or other value (e.g. veteran trees or wood-pasture)
<b>Category B</b>	Trees that might be included in category A, but are downgraded because of impaired condition (e.g. presence of significant though remediable defects, including unsympathetic past management and storm damage), such that they are unlikely to be suitable for retention for beyond 40 years; or trees lacking the special quality necessary to merit the category A designation	See Table 2
<b>Trees of moderate quality</b> with an estimated remaining life expectancy of at least 20 years	Trees present in numbers, usually growing as groups or woodlands, such that they attract a higher collective rating than they might as individuals; or trees occurring as collectives but situated so as to make little visual contribution to the wider locality	Trees with material conservation or other cultural value
<b>Category C</b>	Unremarkable trees of very limited merit or such impaired condition that they do not qualify in higher categories	See Table 2
<b>Trees of low quality</b> with an estimated remaining life expectancy of at least 10 years, or young trees with a stem diameter below 150 mm	Trees present in groups or woodlands, but without this conferring on them significantly greater collective landscape value; and/or trees offering low or only temporary/transient landscape benefits	Trees with no material conservation or other cultural value

Figure 2

**Key**

- 1 Standard scaffold poles
- 2 Heavy gauge 2 m galvanised tube and welded mesh infill panels
- 3 Panels secured to uprights and cross-members with wire ties
- 4 Ground level
- 5 Uprights driven into the ground until secure (minimum depth 0.6 m)
- 6 Standard scaffold clamps

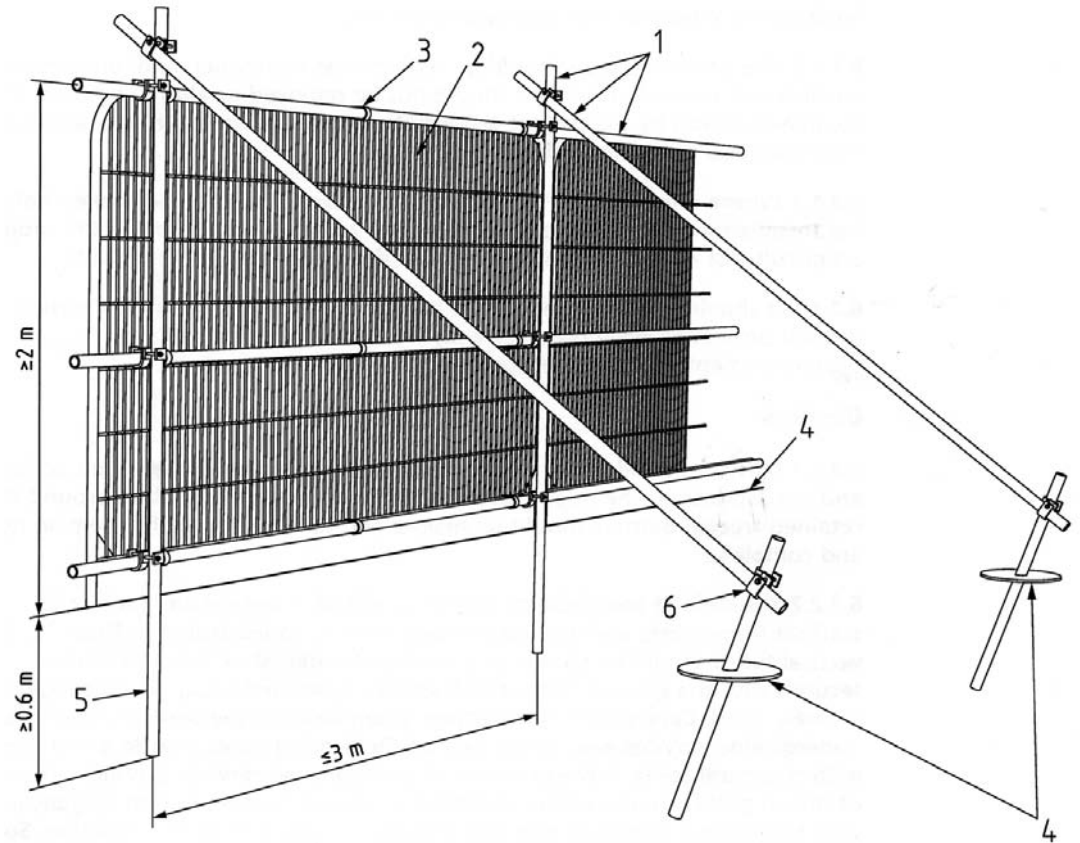

**Examples of above-ground stabilising systems**

Figure 3a

Stabiliser strut with base plate secured with ground pins

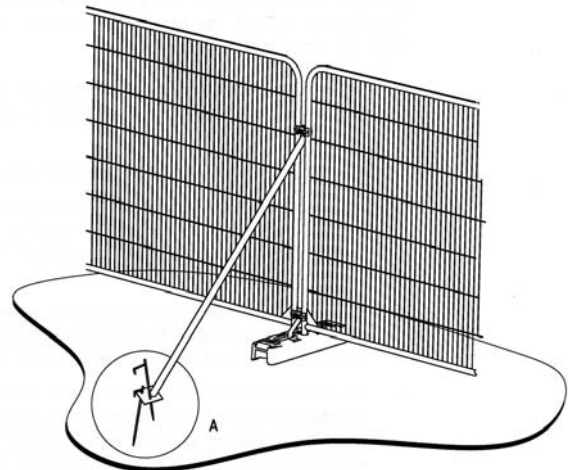
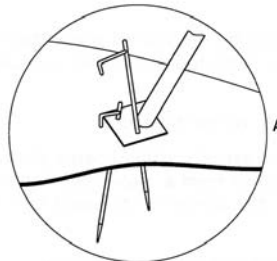
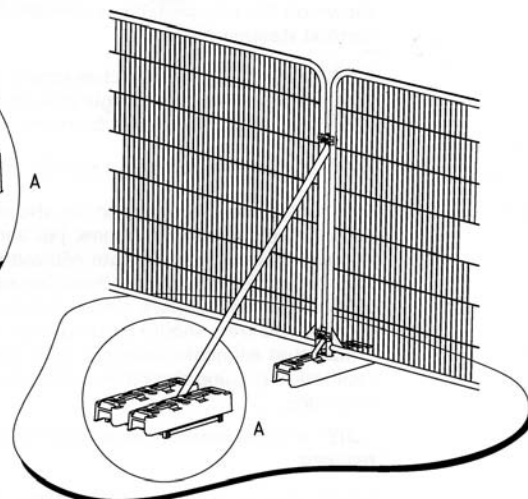
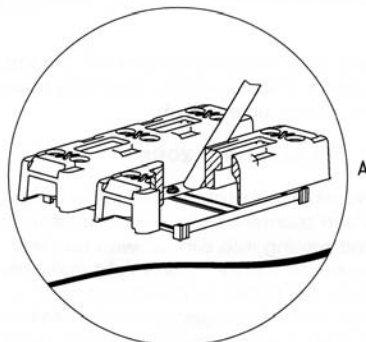

Figure 3b

Stabiliser strut mounted on block tray





T399



Minimal crown lifting



